

GbE+RFC2544+Y.1564

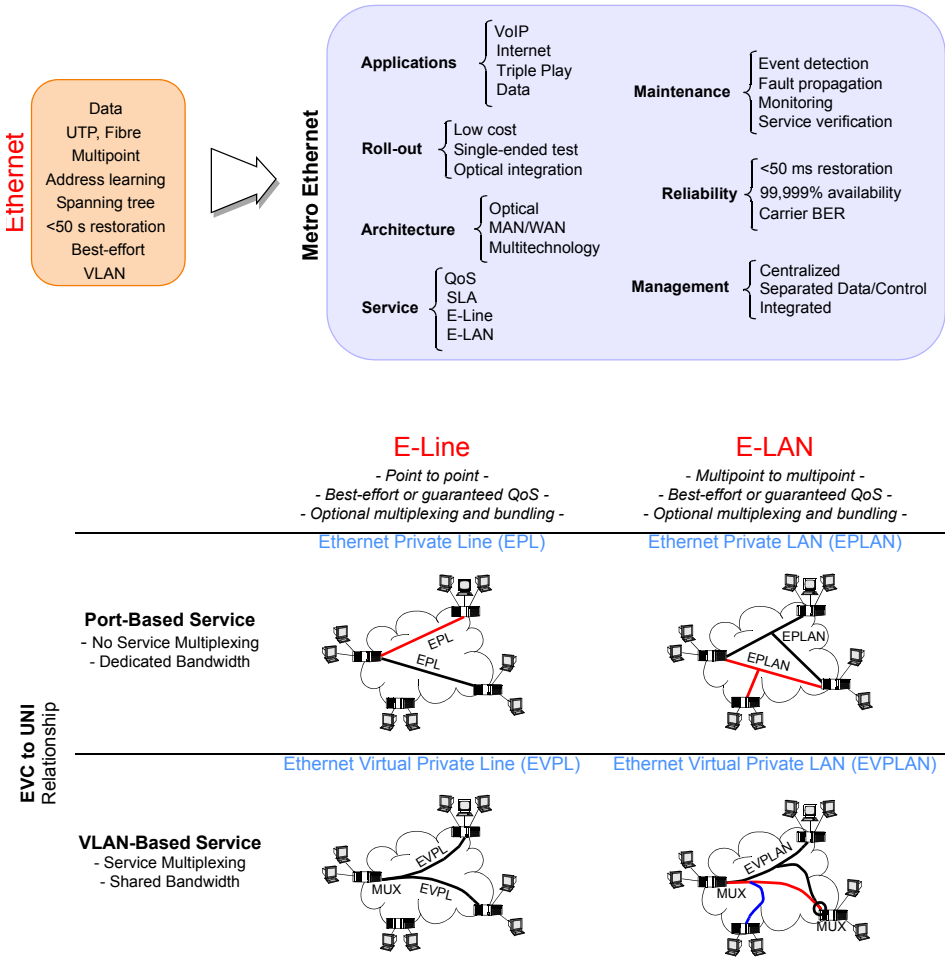

Figure 1 Generic Ethernet Service Type (Metro Ethernet Forum)

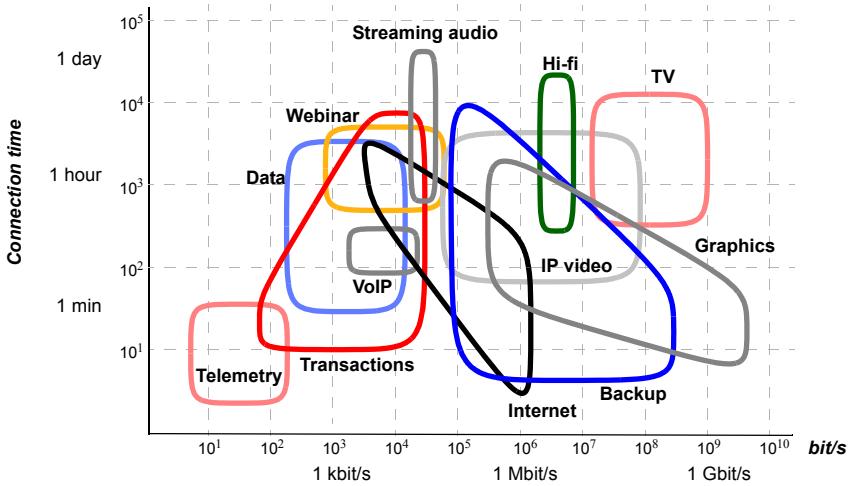

Figure 2 Bandwidth requirements and time for different applications

Application	Bandwidth	Packet Loss (max)	Delay (max)	Jitter (max)
Video conferencing (H.261)	100 kbit/s	1%	150 ms	30 ms
VoIP	12 ~ 106 kbit/s	1%	150 ms	30 ms
Streaming video (MPEG-4)	0.005 ~ 10 Mbit/s	2%	5000 ms	insensitive
Streaming audio (MP3)	32 ~ 320 kbit/s	2%	5000 ms	insensitive
Data	variable	sensitive	insensitive	insensitive

Figure 3 QoS requirements for different applications

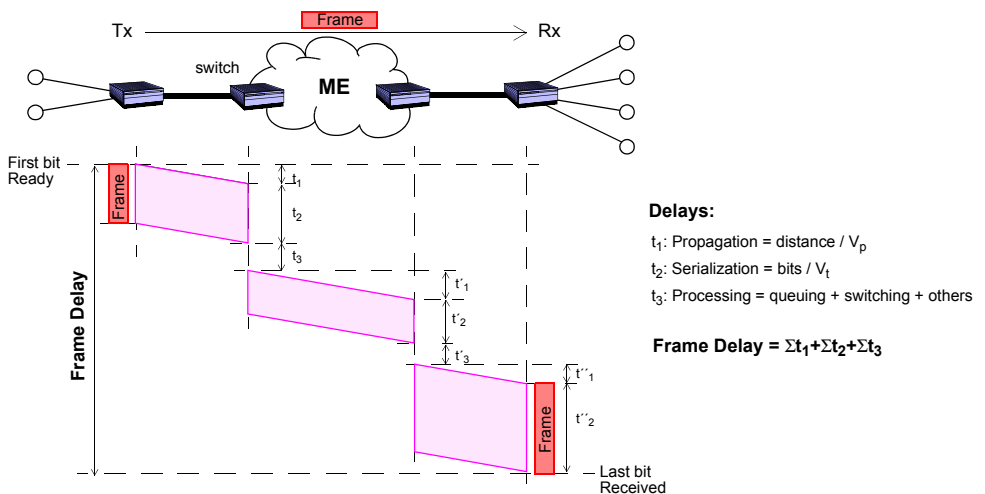
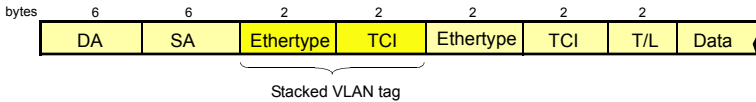

Figure 4 Frame delay is the sum of the delays on each subnet link traversed by the frame

Q-in-Q VLAN Stacking



MAC Address Stacking

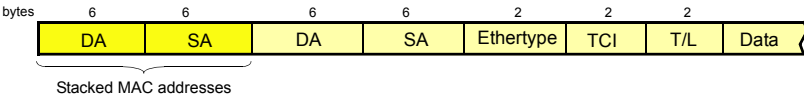
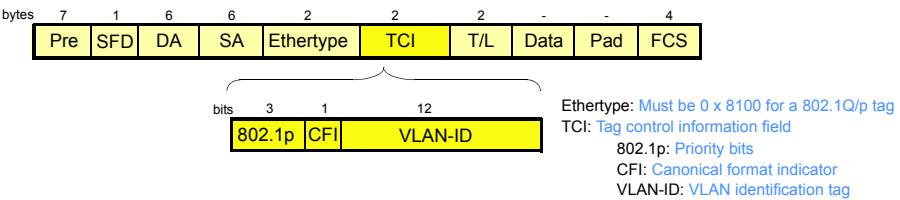
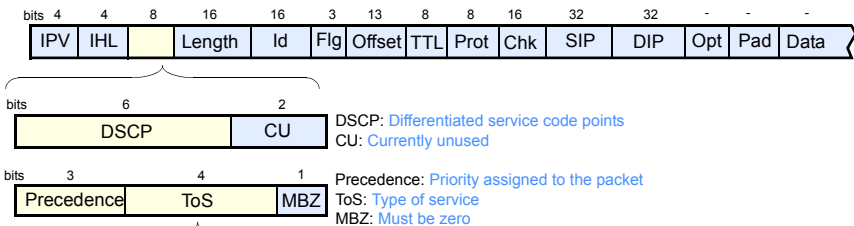

Figure 5 Ethernet framings for Carrier Class Ethernet

IEEE 802.1Q/p



IPv4 Datagram



Binary	Meaning
1000	Minimize delay
0100	Maximize throughput
0010	Maximize reliability
0001	Minimize monetary cost
0000	Normal service

IPV: The IP protocol version
 IHL: IP header length in 32-bit words
 Length: Total packet length
 Id: Identifier to reassemble fragmented packets
 Flg: Fragmentation flags
 Offset: Fragmentation offset
 TTL: Time to live

Prot: Protocol used in the data portion
 Chk: Header checksum
 SIP: Source IP address
 DIP: Destination IP address
 Opt: Options, variable length
 Pad: Padding, fills out the 32-bit words
 Data: Data, variable length, up to 65 535 header bytes

Figure 6 Traffic marking

trTCM algorithm

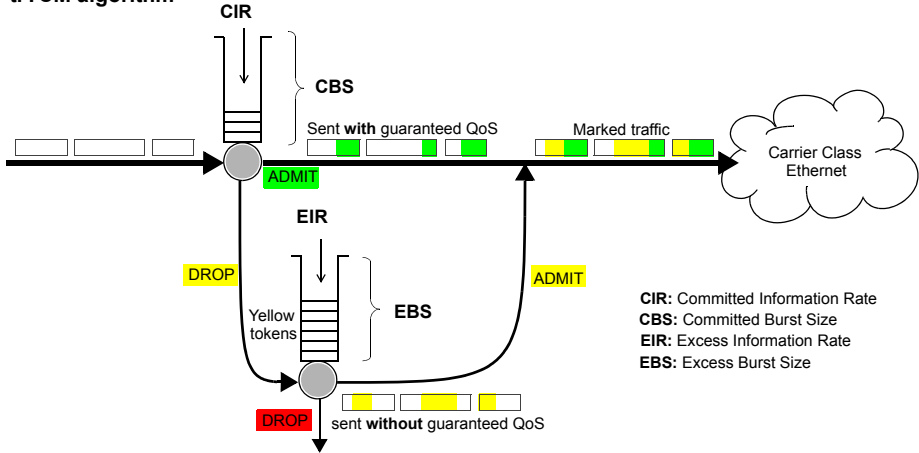
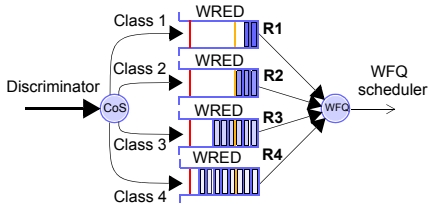

Figure 7 Admission control

AF PHB Provides 4 independent traffic classes with 3 subclasses, each with specific drop precedence

Recommended DSCPs	class 1	class 2	class 3	class 4
Low drop precedence	001010 (AF11)	010010 AF(21)	011010 (AF31)	100010 (AF41)
Medium drop precedence	001100 (AF12)	010100 AF(22)	011100 (AF32)	100100 (AF42)
High drop precedence	001110 (AF13)	010110 AF(23)	011110 (AF33)	100110 (AF43)

1 Implementation based on a WFQ scheduler and WRED congestion control and avoidance in every queue



- The WFQ scheduler allows to share the link fairly between the four classes with configured rates R1, R2, R3 and R4
- The WRED packet dropping policer starts dropping AFx3 first, AFx2 second and AFx1 last when congestion is experienced

EF PHB Provides guaranteed rate with controlled packet loss, delay and jitter

1 Implementation based on a **priority scheduler**

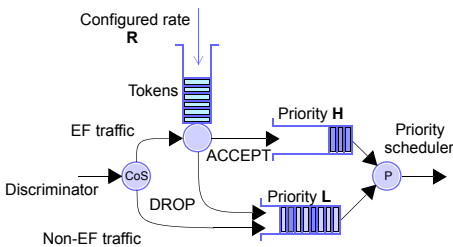

2 Implementation based on a **WFQ scheduler**

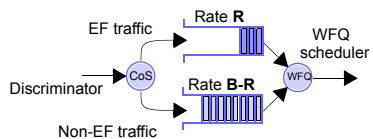
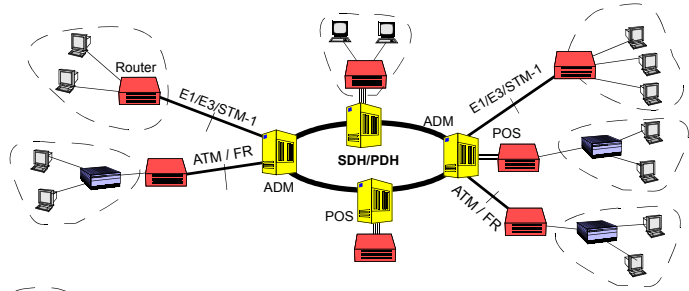
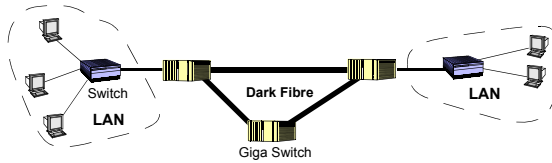

Figure 8 Differentiated services architecture

FR/ATM/Leased Line



Dark Fiber



CWDM/DWDM

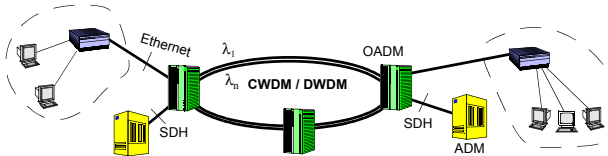

WIS (10Gbit/s)

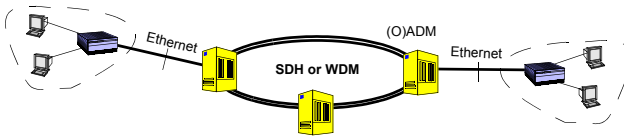

NG-SDH/LAPS

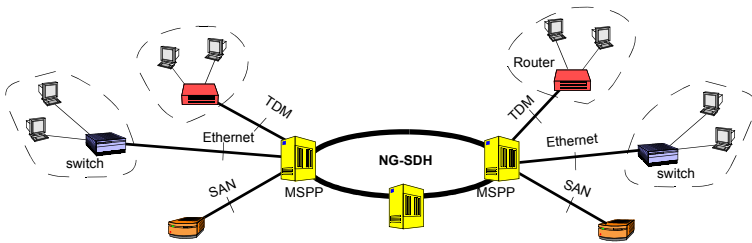

IP	IP	IP	IP	IP	IP
FR / ATM / PPP	Ethernet MAC	Ethernet MAC	Ethernet MAC	Ethernet MAC	Ethernet MAC
PDH / SDH	Ethernet PHY	Ethernet PHY	WIS	Adaptation	MPLS
		WDM	10GbE PHY	SDH / SONET	Adaptation
FR / ATM / Line (not Ethernet!)	Dark Fiber	WDM	WIS (SDH framing)	LAPS / NG SDH	MPLS

Figure 9 Carrier Ethernet topologies and protocol towers

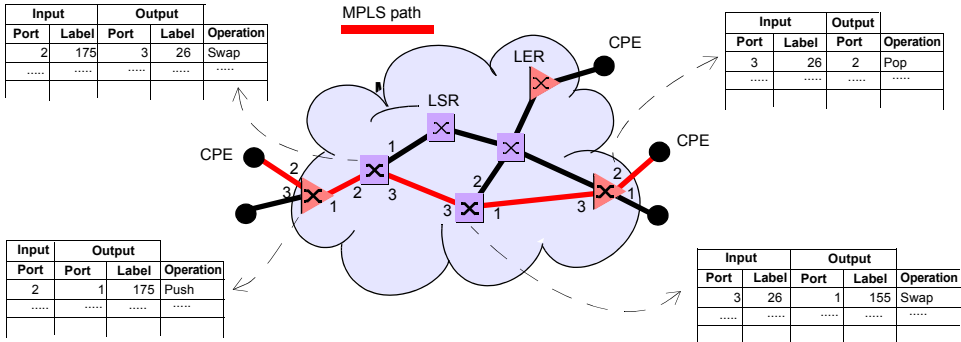
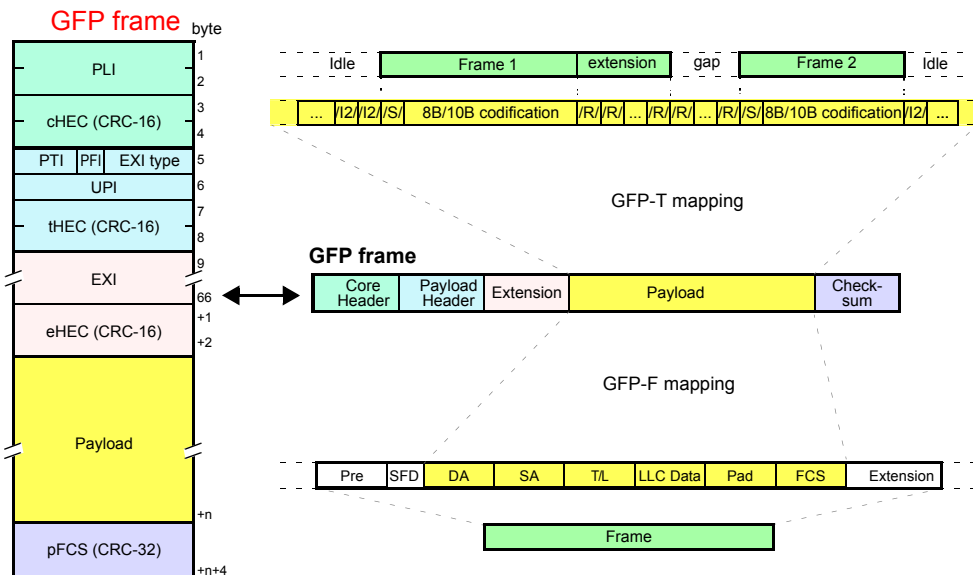

Figure 10 MPLS networks



PLI: PDU Length Indicator
 cHEC: Core HEC protection
 PTI: Payload type Identifier
 000: client data
 100: client management
 PFI: Payload FCS Indicator
 1: presence of FCS
 0: absence
 EXI: Extension Header Identifier
 0000: Null
 0001: Linear
 0010: Ring
 UPI: User Payload Identifier (PTI=0)
 01x: Ethernet (GFP-F)
 06x: Gigabit Ethernet (GFP-T)

tHEC: Type HEC protection
 EXI: Extension Header Identifier

Null EXI	Type	Linear EXI type	Type
	tHEC		tHEC
			CID
			Spare
			eHEC

tHEC: Type HEC protection
 CID: Channel ID for submultiplexing
 eHEC: Extension HEC protection
 Payload: Space for the framed PDU
 pFCS: Payload FCS

Preamble: Synchronisation pattern
 SFD: Start Frame Delimiter
 DA: Destination Address
 SA: Source Address
 T/L: Type/Length
 LLC: Payload
 Pad: Ensures a minimum frame size
 FCS: Frame Check Sequence

Figure 11 Ethernet over NG SDH/SONET by means of GFP adaptation

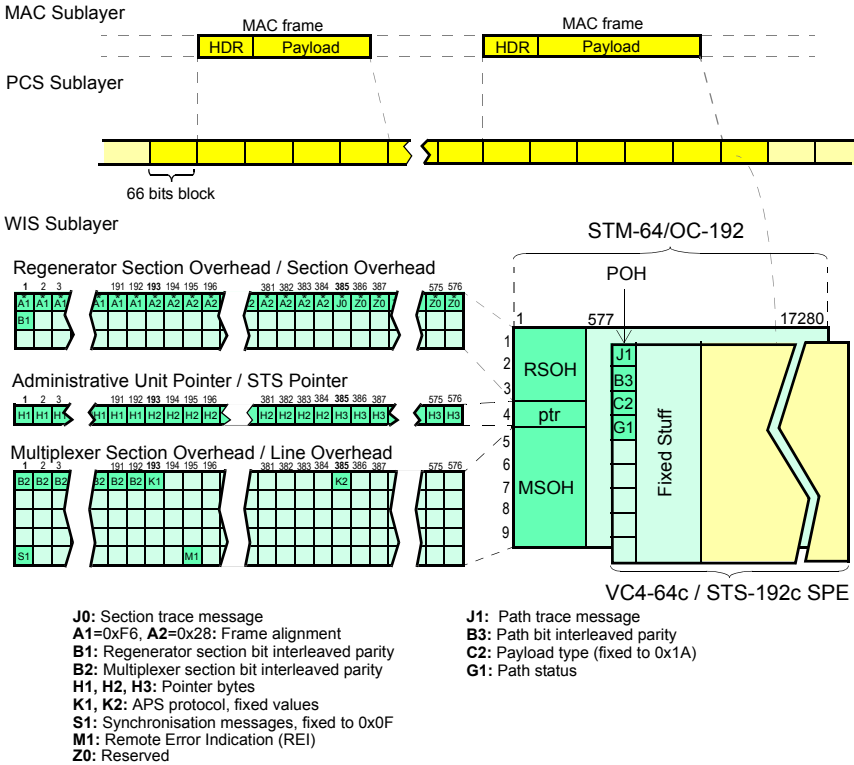
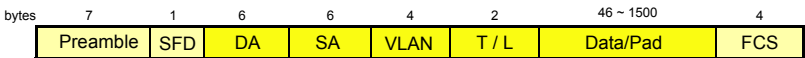
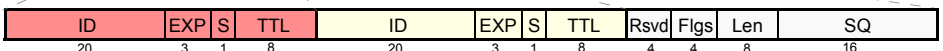
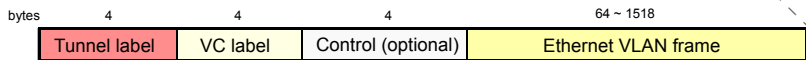

Figure 12 WAN interface sublayer (WIS) for 10G-BASE-W

Tagged Ethernet VLAN Frame



Labeled MPLS Frame



- Tunnel label:** LSP used in the MPLS domain
- **ID:** LSP Identifier
 - **EXP:** Class of Service
 - **S:** Stack
 - **TTL:** Time-to-live
- VC label:** Forwarding info at egress LSR
- **ID:** LSP Identifier
 - **EXP:** Class of Service
 - **S:** Stack
 - **TTL:** Time-to-live
- Control:** Extra control information
- **Rsvd:** Reserved
 - **Flgs:** Protocol-specific control information
 - **Len:** Packet length
 - **SQ:** Sequence number

Figure 13 MPLS encapsulation of Ethernet frames

Acronyms

AS	Assured Forwarding	MMF	Multimode Fibre
AU	Administrative Unit	MPLS	Multiprotocol Label Switching
CBS	Committed Burst Size	MSOH	Multiplexer Section Overhead
CIR	Committed Information Rate	NG-SDH	Next Generation SDH
CoS	Class of Service	OC- <i>n</i>	Optical Carrier, level <i>n</i>
CPE	Customer Premises Equipment	PCS	Physical Coding Sublayer
CRC	Cyclic Redundancy Check	PDU	Payload Data Unit
DSCP	Differentiated Services Code Point	PHB	Per Hop Behavior
DWDM	Dense Wavelength Division Multiplexing	POH	Path Overhead
EBS	Excess Burst Size	QoS	Quality of Service
EF	Expedited Forwarding	RSOH	Regenerator Section Overhead
EIR	Excess Information Rate	SDH	Synchronous Digital Hierarchy
E-LAN	Ethernet LAN	SFD	Start of Frame Delimiter
E-Line	Ethernet Line	SMF	Single Mode Fiber
EoS	Ethernet over SDH/SONET	SONET	Synchronous Optical Network
EPL	Ethernet Private Line	SPE	Synchronous Payload Envelope
EPLAN	Ethernet Private LAN	STM- <i>n</i>	Synchronous Transport Module, level <i>n</i>
EVC	Ethernet Virtual Circuit	STP	Shielded Twisted Pair
EVPL	Ethernet Virtual Private Line	STS- <i>n</i>	Synchronous Transport Signal, level <i>n</i>
EVPLAN	Ethernet Virtual Private LAN	ToS	Type of Service
FCS	Frame Check Sequence	trTCM	two-rate Three-Colour Marker
GbE	Gigabit Ethernet	TTL	Time To Live
GFP	Generic Frame Procedure	UNI	User-to-Network Interface
HEC	Header Error Control	UTP	Unshielded Twisted Pair
IP	Internet Protocol	VC	Virtual Circuit

- Advanced Counts: Up to 8 filters at MAC, IP, TCP/UDP, Arbitrary [mask + offset]
- Y.1564 (e-SAM) FTD, 2-way FDV, FDV, 2-way FTD, FLR, SES, PEU and PEA
- Y.1731 QoS statistics
- 2 x SFP + 2 x RJ45 interfaces
- Symmetrical & Asymmetrical RFC2544 test
- FCS error insertion in passthrough mode
- L1/L2/L3/L4 loopback
- Multistreams for IPTV, VoIP, and Critical Data verification
- Q-in-Q for demarcation tests
- MPLS support
- Scan MAC/IP/VLAN/QinQ

Made in EU
designed in 2012

Field GbE test

ALBEDO Ether.Giga is an Ethernet & IP tester equipped with all the features of legacy testers such as BER and RFC2544, plus the new ones like Y.1564, Y.1731, and FCS error insertion in pass mode therefore it is capable to verify the QoS and SLA of new Multiplay services offering field technicians tools to quickly and easily validate and troubleshoot Ethernet services, including multiplay applications such as VoIP, IPTV, VoD, high-performance Computing, Virtualization Services, Data Centers and Storage that require significant levels of bandwidth

