

# Net.Time $\phi$ Applications



*Net.Time is a Grandmaster and Boundary clock that supports PTP and NTP over PRP and multiple input/output options such as IRIG-B, 1PPS, ToD and SyncE to satisfy all timing needs of power utility, enterprise and telecom applications*

*Just in Time*

**ALBEDO**  
Telecom

# ALBEDO a Global manufacturer of Testers & Timing appliances



# Net.Time $\phi$ a substation clock

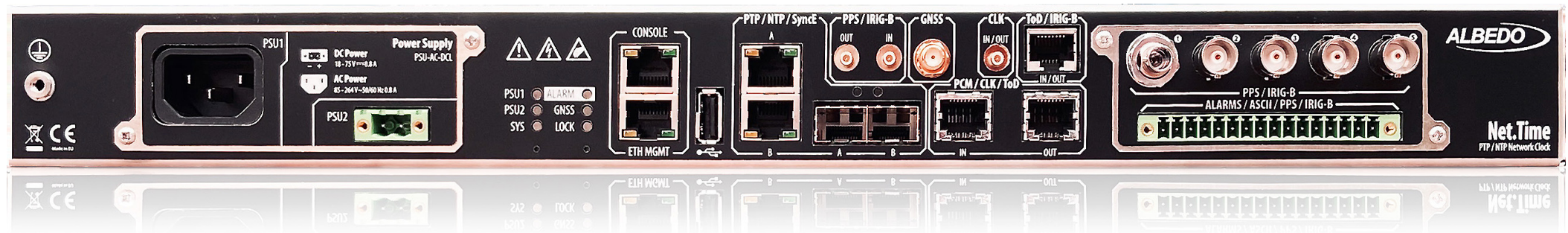

Net.Time  $\phi$  is a PTP/NTP over PRP clock designed to facilitate the integration of conventional substations with the new IEC 61850 standards by offering a wide variety of reference inputs and outputs. It can be equipped with a Rubidium oscillator, the best option for time quality especially in hold-over. It is powerful as it supports up to 22 simultaneous outputs, and very flexible because it can be disciplined with multiple back-up inputs.

# About Synchronization

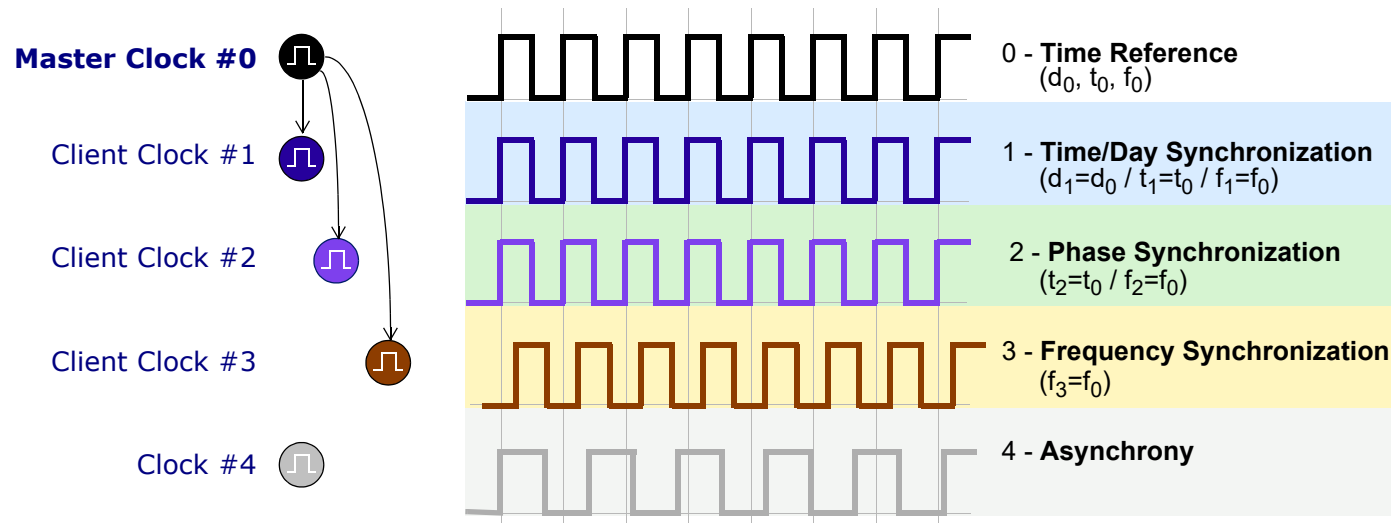

Synchronization aims to discipline clocks in a network to a common time reference.

- **Master Clock #0** is the time reference defined by a Day ( $d_0$ ), Phase ( $p_0$ ) and Frequency ( $f_0$ )
- **Client Clock #1** is disciplined to the Master on Day ( $d_0$ ), Phase ( $p_0$ ) and Frequency ( $f_0$ )
- **Client Clock #2** is disciplined to the Master only on Phase ( $p_0$ ) and Frequency ( $f_0$ )
- **Client Clock #3** is disciplined to the Master only on Frequency ( $f_0$ )
- **Clock #4** is not disciplined at all

Even when initially set accurately, real clocks will differ after some amount of time due to clock drift, caused by clocks counting time at slightly different rates.

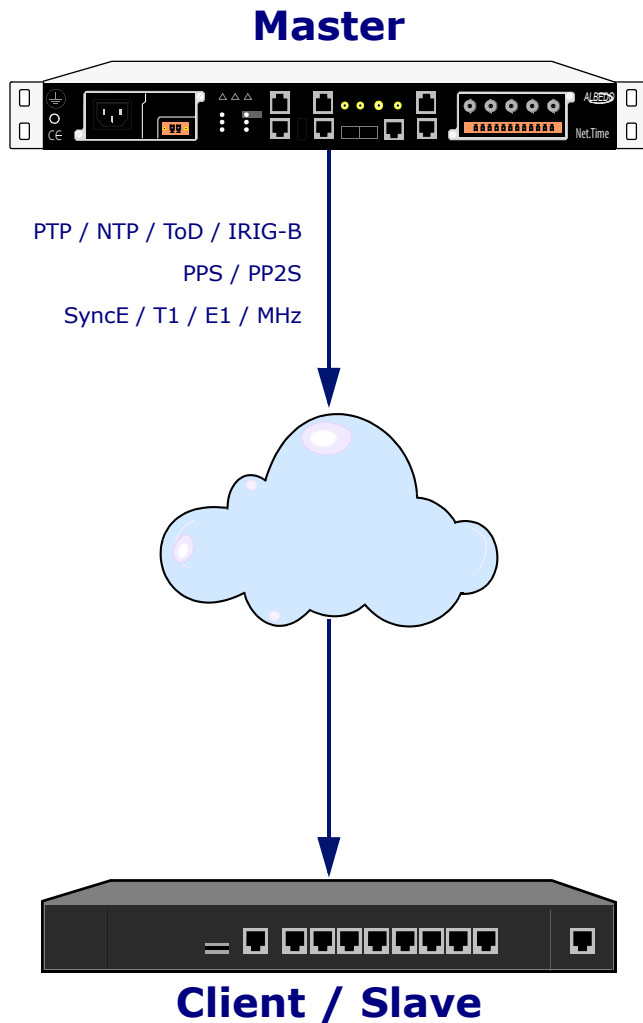

Net.Time  $\phi$  can synchronize by means of several signals that can be grouped according the following hierarchy.

**Time/Day Synchronization** which is the most comprehensive as provide day, phase & frequency:

- PTP
- NTP
- ToD
- IRIG-B
- DCF77

**Phase or Time Synchronization:** can only provide phase and frequency:

- PPS
- PP2S

**Frequency Synchronization:** can only provide frequency:

- T1
- E1
- SyncE
- MHz



Originally DCF77 is a German long-wave time signal and standard-frequency radio station that carries an amplitude-modulated data signal repeated every minute.

- M: Start
- R: service request to the DCF77 system
- A1: forthcoming change CET to/from CEST
- Z1, Z2: time zone indication
- A2: Leap second warning bit
- Pi: parity bits
- S: Start of time information minute, hour, day, week day, months, year

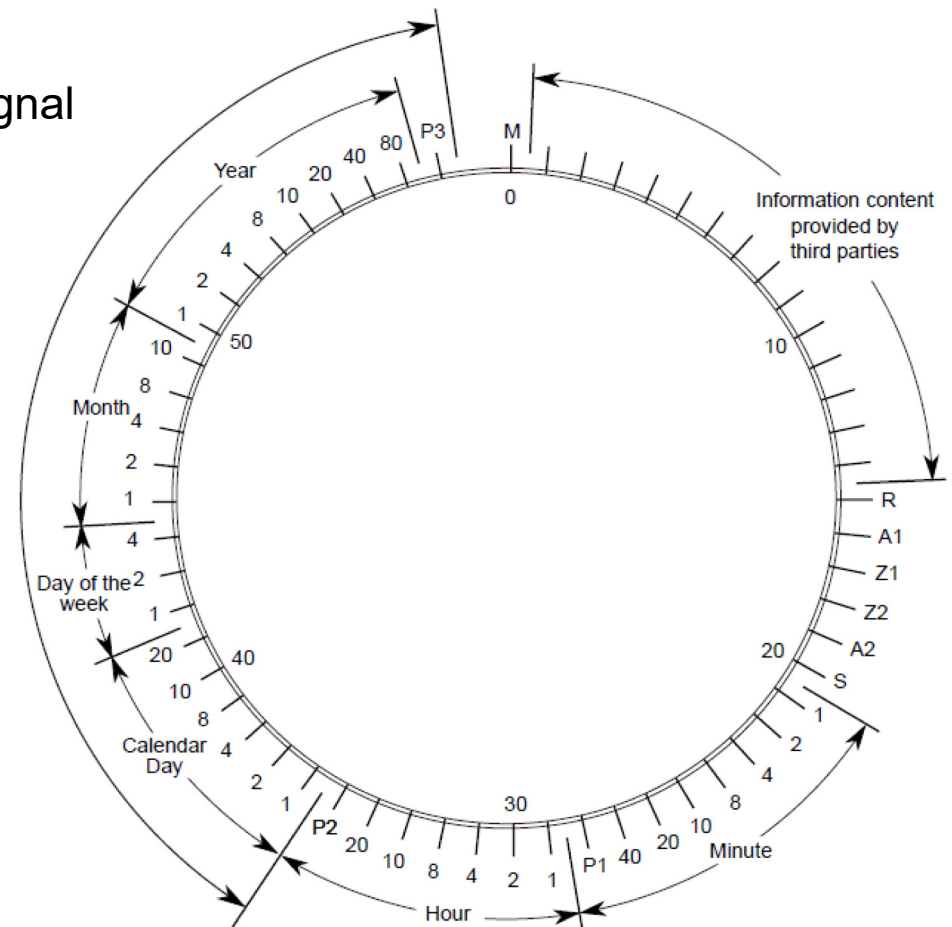

A lot of substations generate the DCF77 signal synchronized with GNSS (or the time reference used in the node). The accuracy of DCF77 is good enough for SCADA and wall clocks and is still used.

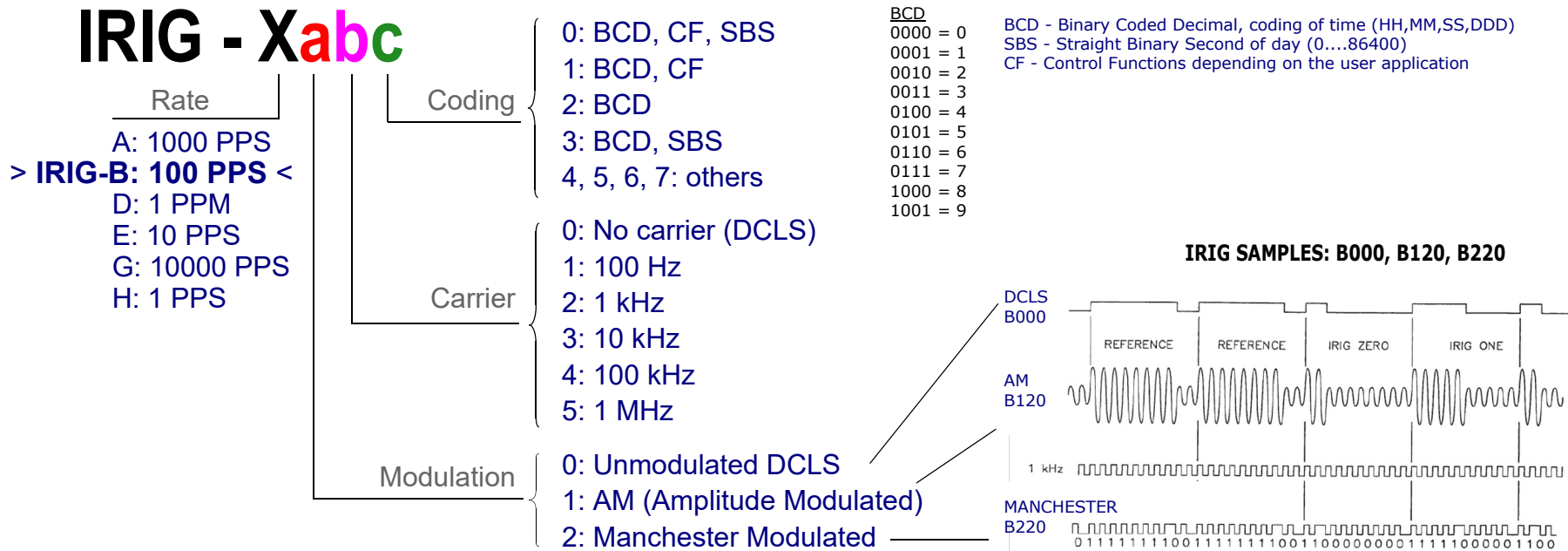

IRIG-B sends a timing signal at 100 pulse/sec rate including Year, Day, Hour, Min, Sec data with an update rate of one second direct or over a Carrier:

### Unmodulated DCLS IRIG-B offers several transmission alternatives

- TTL-level signal over coaxial cable or shielded twisted-pair cable
- Multi-point distribution using 24 Vdc for signal and control power
- RS-485 differential signal over shielded twisted-pair cable
- RS-232 signal over shielded cable (short distances only)
- Optical fiber

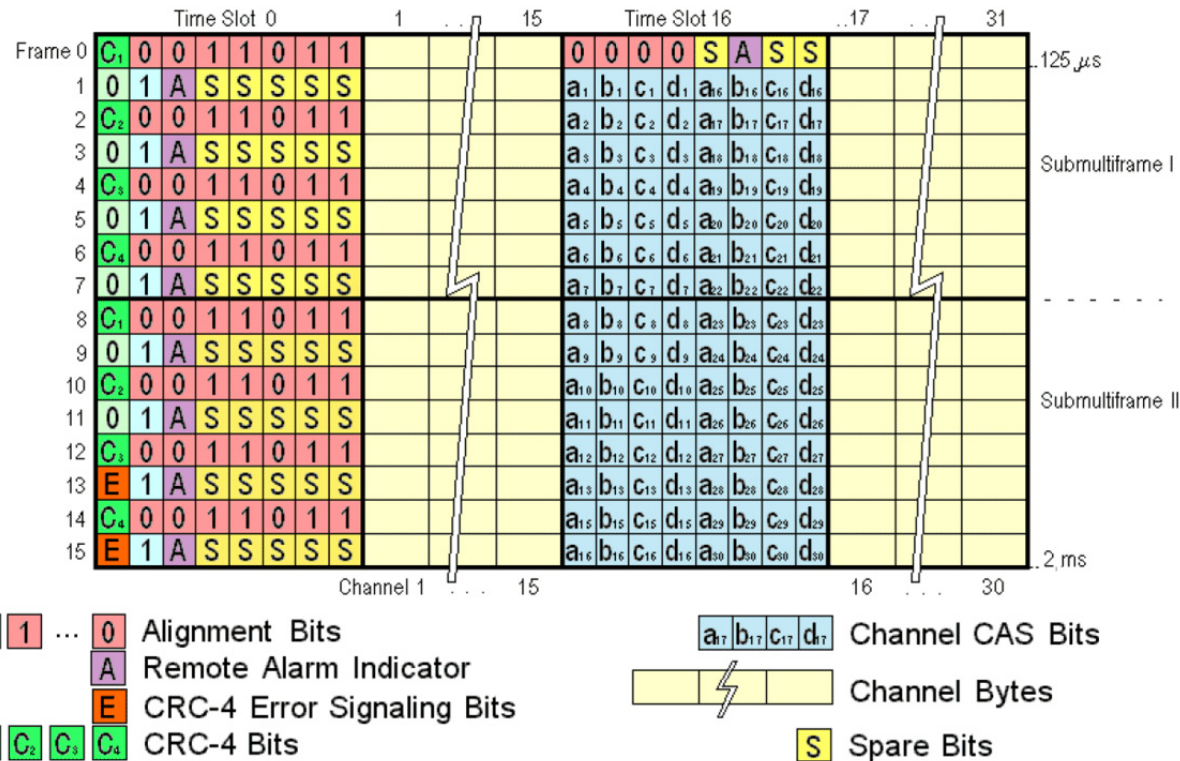

- The T-carrier is a hardware specification for carrying multiple time-division multiplexed (TDM) telecommunications channels over a single four-wire transmission circuit. It was developed by AT&T at Bell Laboratories ca. 1957 and first employed by 1962 for long-haul pulse-code modulation (PCM) digital voice transmission with the D1 channel bank.
- The E-carrier is a member of the series of carrier systems developed for digital transmission of many simultaneous telephone calls by time-division multiplexing. The European Conference of Postal and Telecommunications Administrations (CEPT) originally standardized the E-carrier system.



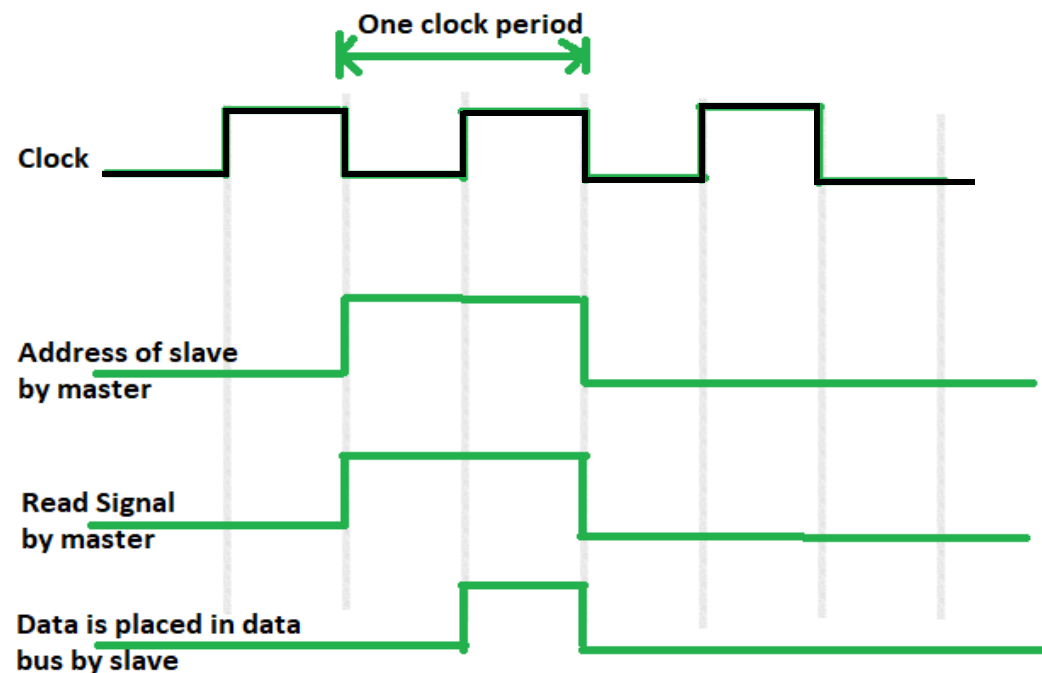

Often known as BITS (Building Integrated Timing Supply) describe a building-centric timing system, the BITS system efficiently manages the number of timing interfaces within a structure providing external timing connections typically deployed as T1 or E1 frequencies but also can refer to MHz and then distributing timing to all circuits that require it.

There are several signals suitable for transporting synchronization:

- Analog, of 1,544 and 2,048 kHz
- Digital, of 1,544 and 2,048 kbit/s

In both cases it is extremely important for the clock signal to be continuous.

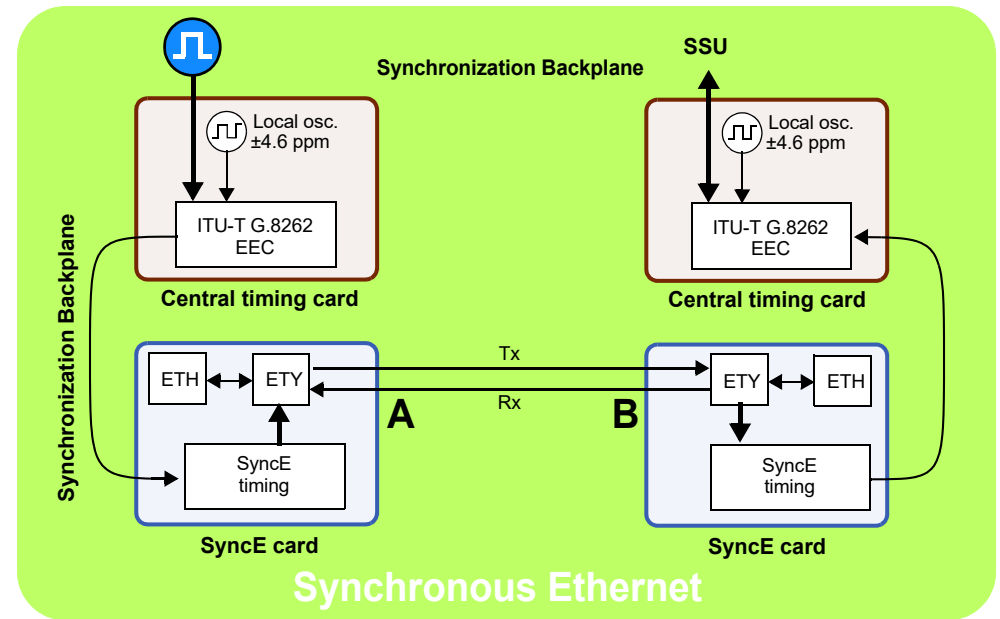
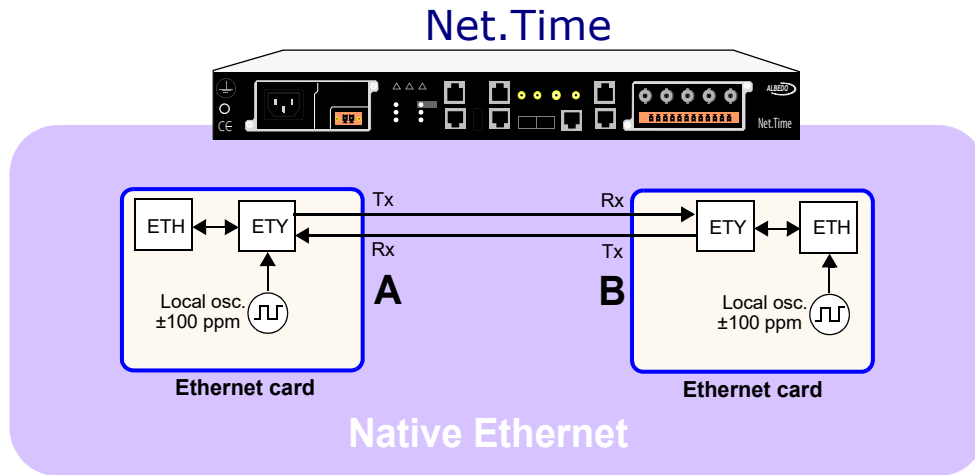

SyncE is not part of the IEC 61850 but is required in the Power Grid and implemented by Net.Time

## 1. PHY Ethernet

- Rx gets synchronized using the input line [Tx (port B) >>> Rx (port A)]
- BUT there is no time relation between the Rx and Tx of the same Port

## 2. SyncE PHY (physical layer)

- Rx gets synchronized using the recovered clock
- Tx uses a traceable reference clock

## Network Time Protocol support)

- Port A: NTP server @ 1000 transactions / s
- Port B: NTP client and time ref.

## NTP versions

- NTPv3 (RFC 1305) server & client
- NTPv4 (RFC 5905) server & client
- SNTPv3 (RFC 1769) server

## Configuration

- Maximum/ Minimum polling interval

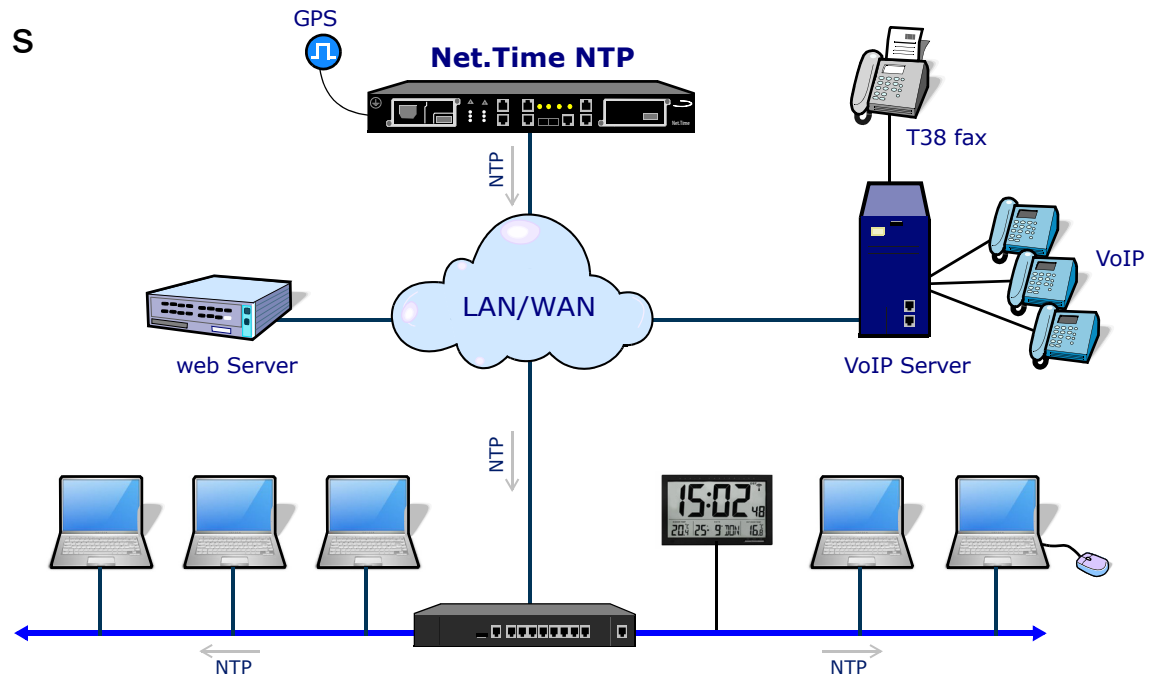

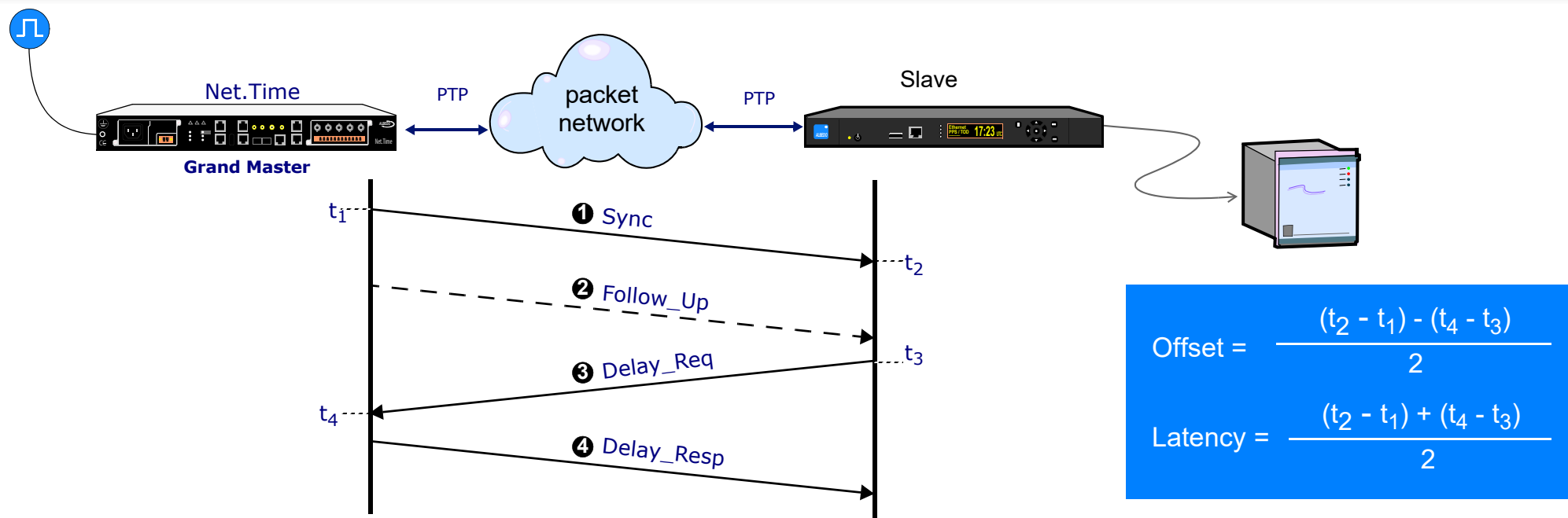

It is a cost-efficient solution and can be applied on the basis of the existing Ethernet network in a substation. PTP (IEEE 1588) applies master/slave time synchronization mechanisms and supports hardware time stamps. The basic parameters of Latency / Offset are computed from the  $t_{1...4}$  stamps.

- Grandmaster sends a series of messages with date and time to client-clocks
- Client-clocks compensate the delays and get synchronized with the Master
- Frequency is then recovered with a precise time-of-d
- PTP prevents error accumulation in cascaded topologies, fault tolerance and enhances the flexibility and PTP can use an existing Ethernet reducing cabling costs and requires just a few resources.

# Timing Evolution

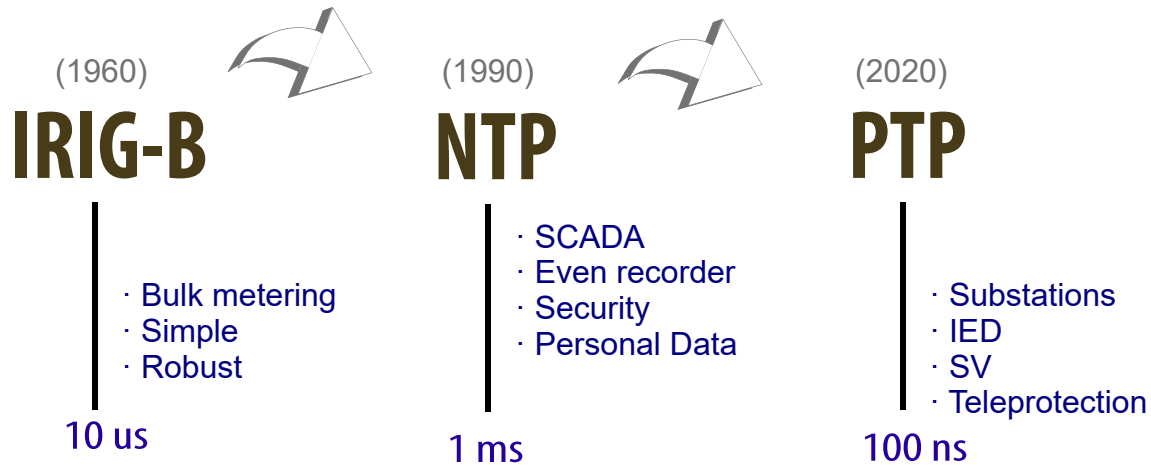

Power Grid have a combination of **all them**

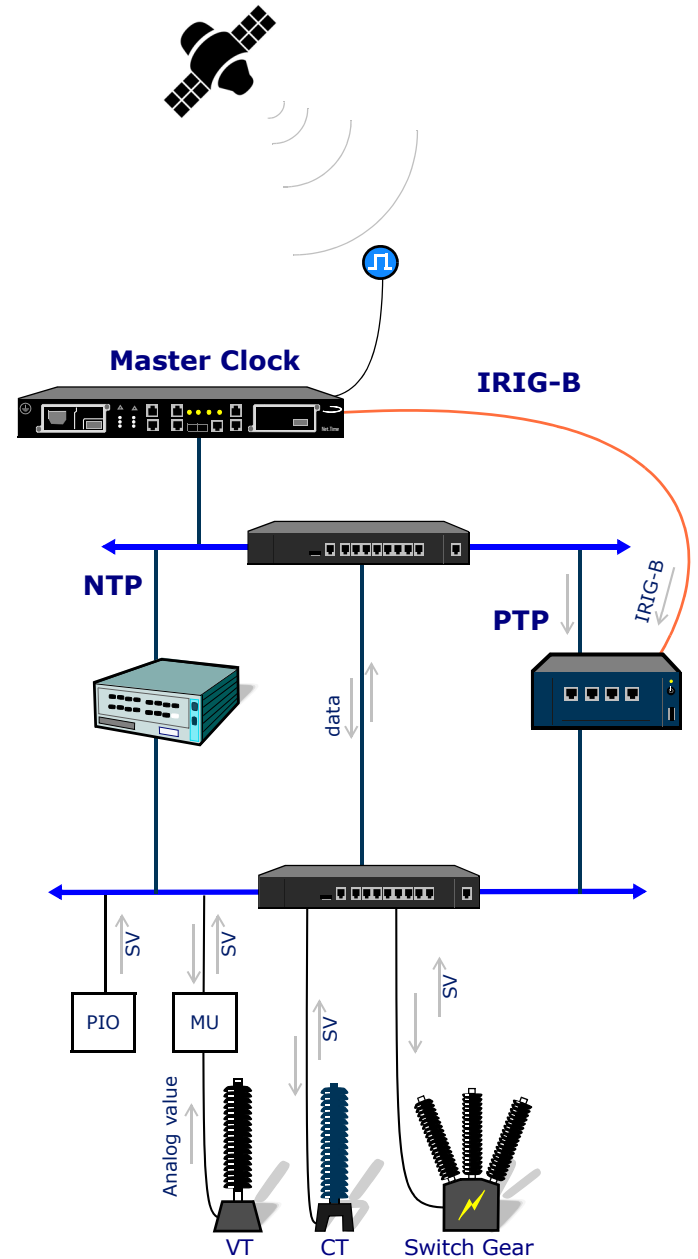



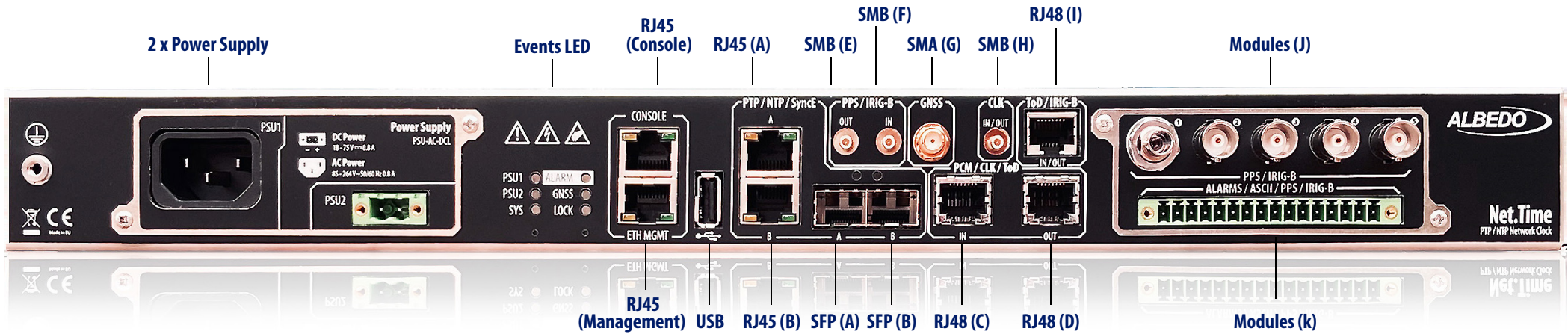

from **10Mb/s** up to **1Gb/s**

- 19" / ETSI/1U/201 mm rack mount
- Fanless operation
- Weight: 1.9 kg / 4.2 lb
- Redundant power supply
- 6 x LEDs
- USB: Software and firmware upgrade
- Storage temperature: -40 ~ +85°C
- Operating: -25 ~ +75°C (10 ~ 95% RH non condensing)
- Slot for 5 x Optional Modules

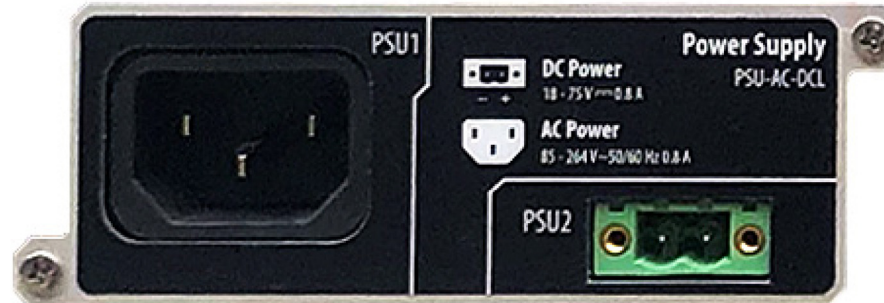

## Multiple combinations

- Single: AC / DC / DCAC
- Double: AC+AC, AC+DC, DC+DC, AC+DCAC, AC+DCAC, DCAC+DCAC

## Options

- AC: 100 ~ 240 Vac, 50- 60 Hz (IEC 60320 C13/C14)
- DC: 18 ~ 75 Vdc (2-pin 5.1 mm)
- AC/DC: 85 - 264 VAC or 10 - 370 VDC (2-pin 5.1 mm)

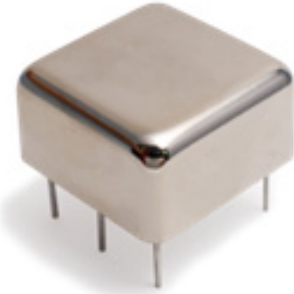

## Internal Oscillator

- Rubidium better than  $\pm 5.0 \text{ e-}11$
- OCXO better than  $\pm 0.1 \text{ ppm}$
- Internal time reference better than  $\pm 2.0 \text{ ppm}$

## Hold-over

- Rubidium:  $1\mu\text{s}$  / 24 hours
- OCXO:  $10\mu\text{s}$  / 12 hours

**best accuracy in market**

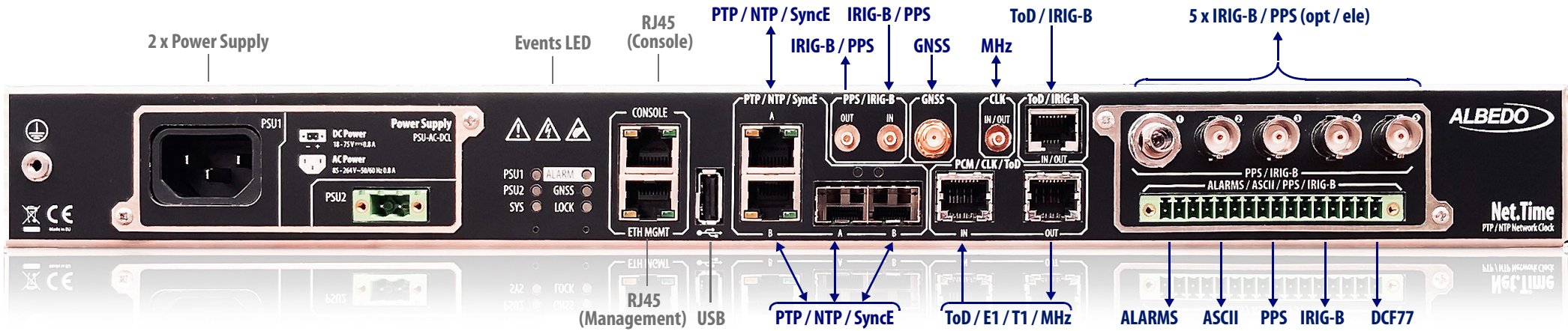

	GNSS	PTP	NTP	ToD	IRIGB	PPS	PP2S	SyncE	T1/E1	MHz	ASCII	DCF77	Alarm
RJ45 (A)		out	out					in/out					
RJ45 (B)		in	in					in/out					
SPF (A)		out	out					in/out					
SPF (B)		in	in					in/out					
SMB (E)					out	out	out						
SMB (F)					in	in	in						
SMB (H)										in/out	in/out		in/out
SMA (G)	in												
RJ48 (I)				in/out	in/out								
RJ48 (C)				in				in	in	in	in		in
RJ48 (D)				out				out	out	out	out	out	out
BNC/ST (J)					out	out	out				out		out
Socket (K)					out	out	out				out		out

# Universal Time Protocol Translator

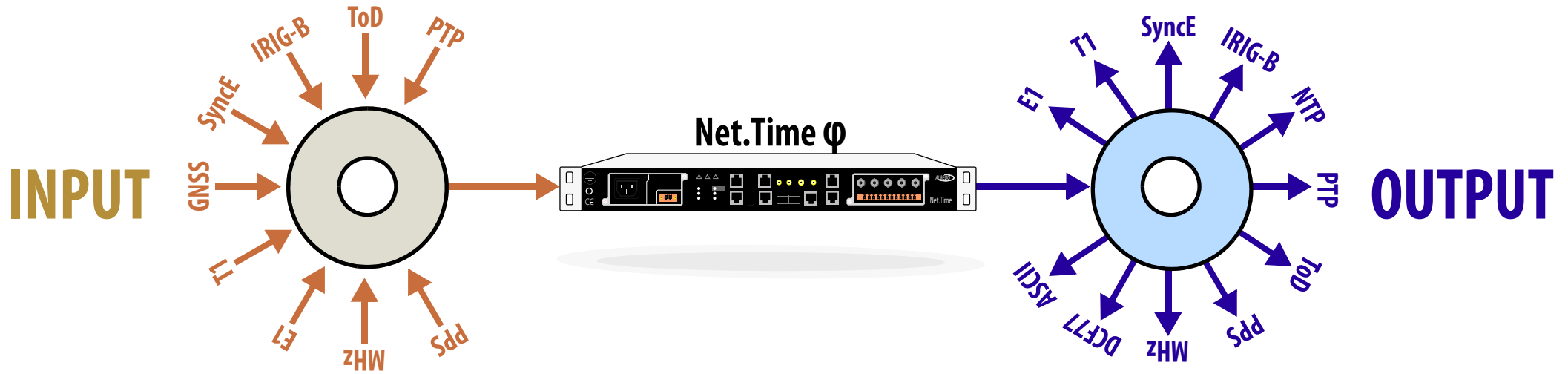

		Input Signals							
		GNSS	PTP	ToD	IRIG-B	PPS	SyncE	T1/E1	MHz
Output Signals	PTP	yes	yes	yes	yes	yes	yes	yes	yes
	NTP	yes	yes	yes	yes	yes	yes	yes	yes
	ToD	yes	yes	yes	yes	yes	yes	yes	yes
	IRIG-B	yes	yes	yes	yes	yes	yes	yes	yes
	PPS	yes	yes	yes	yes	yes	yes	yes	yes
	SyncE	yes	yes	yes	yes	yes	yes	yes	yes
	E1/T1	yes	yes	yes	yes	yes	yes	yes	yes
	DCF77	yes	yes	yes	yes	yes	yes	yes	yes
	MHz	yes	yes	yes	yes	yes	yes	yes	yes



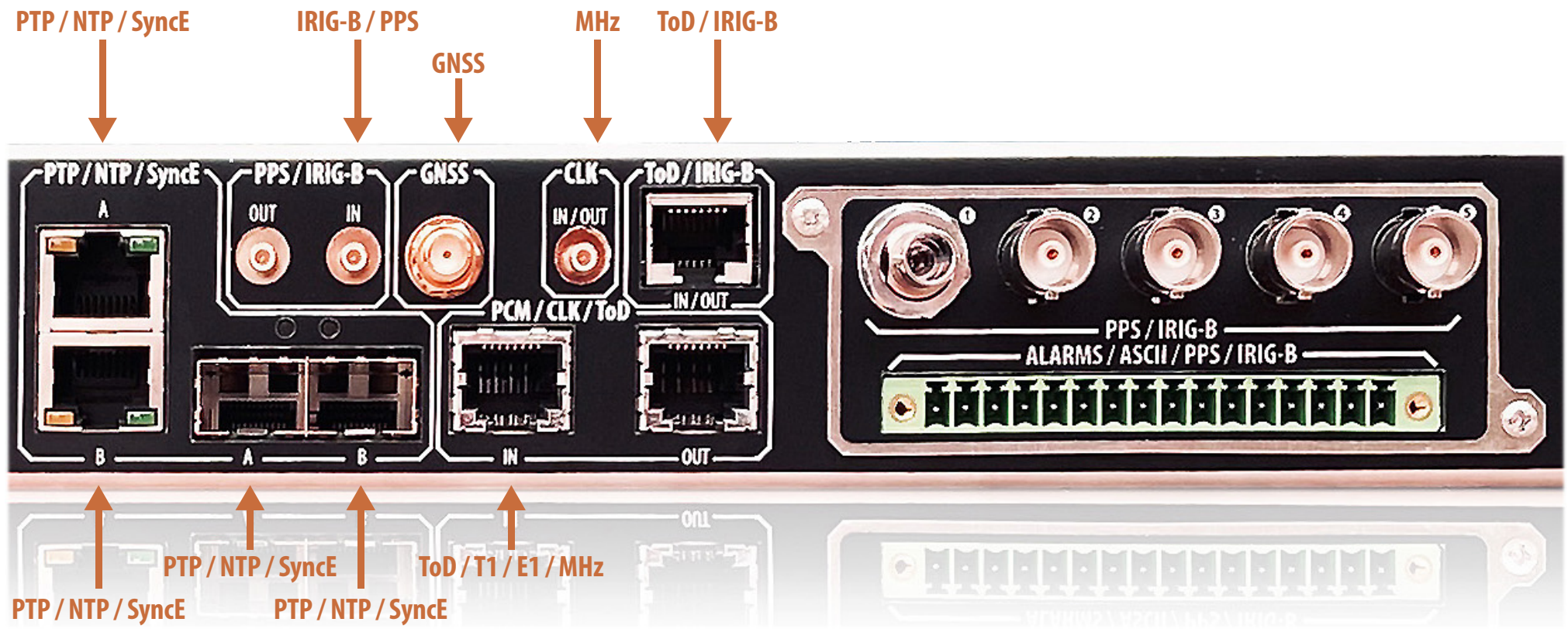

up to 10 different time references

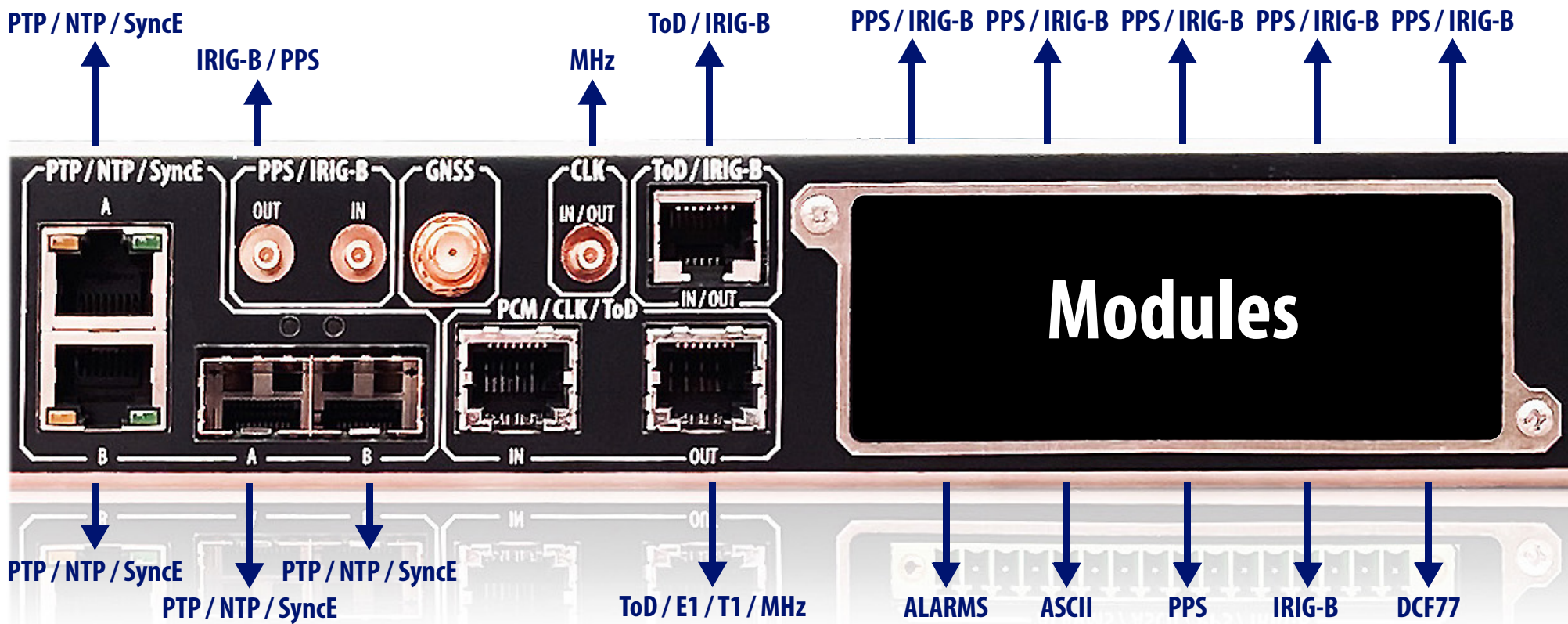

up to **22 simultaneous** Outputs

E1/T1 are only a Frequency references therefore can only discipline Frequency signals.

### Rates

- 1544 Mb/s
- 2048 Mb/s

Can discipline

- SyncE
- T1/E1
- MHz: 10, 5, 2.048 and 1.544 MHz

any **input to output**

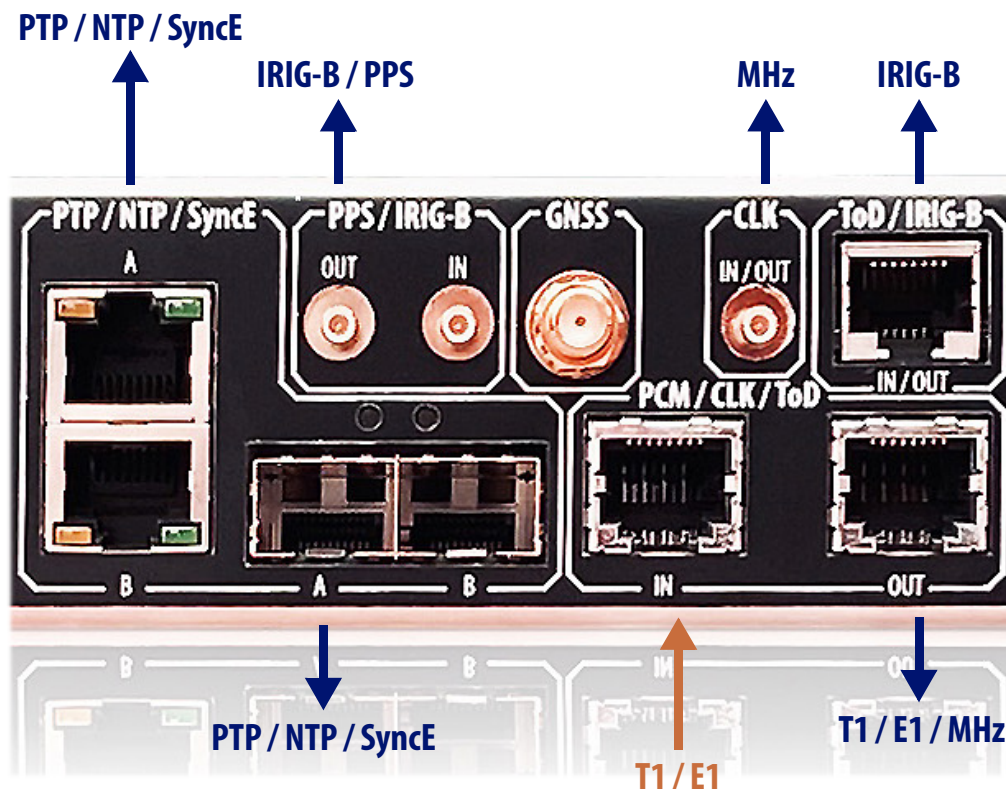

	GNSS	PTP	NTP	ToD	IRIGB	PPS	PP2S	SyncE	T1/E1	MHz
RJ45 (A)		out	out						in/out	
RJ45 (B)		in	in						in/out	
SPF (A)		out	out						in/out	
SPF (B)		in	in						in/out	
SMB (E)					out	out	out			
SMB (F)					in	in	in			
SMB (H)										in/out
SMA (G)	in									
RJ48 (I)				in/out	in/out					
RJ48 (C)				in					in	in
RJ48 (D)				out					out	out

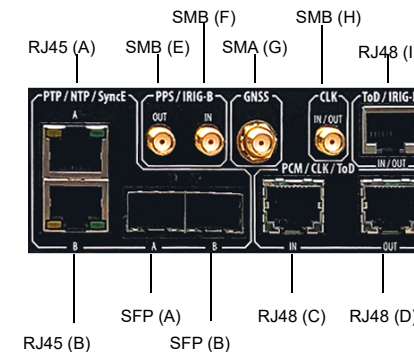



# 5 x Modules

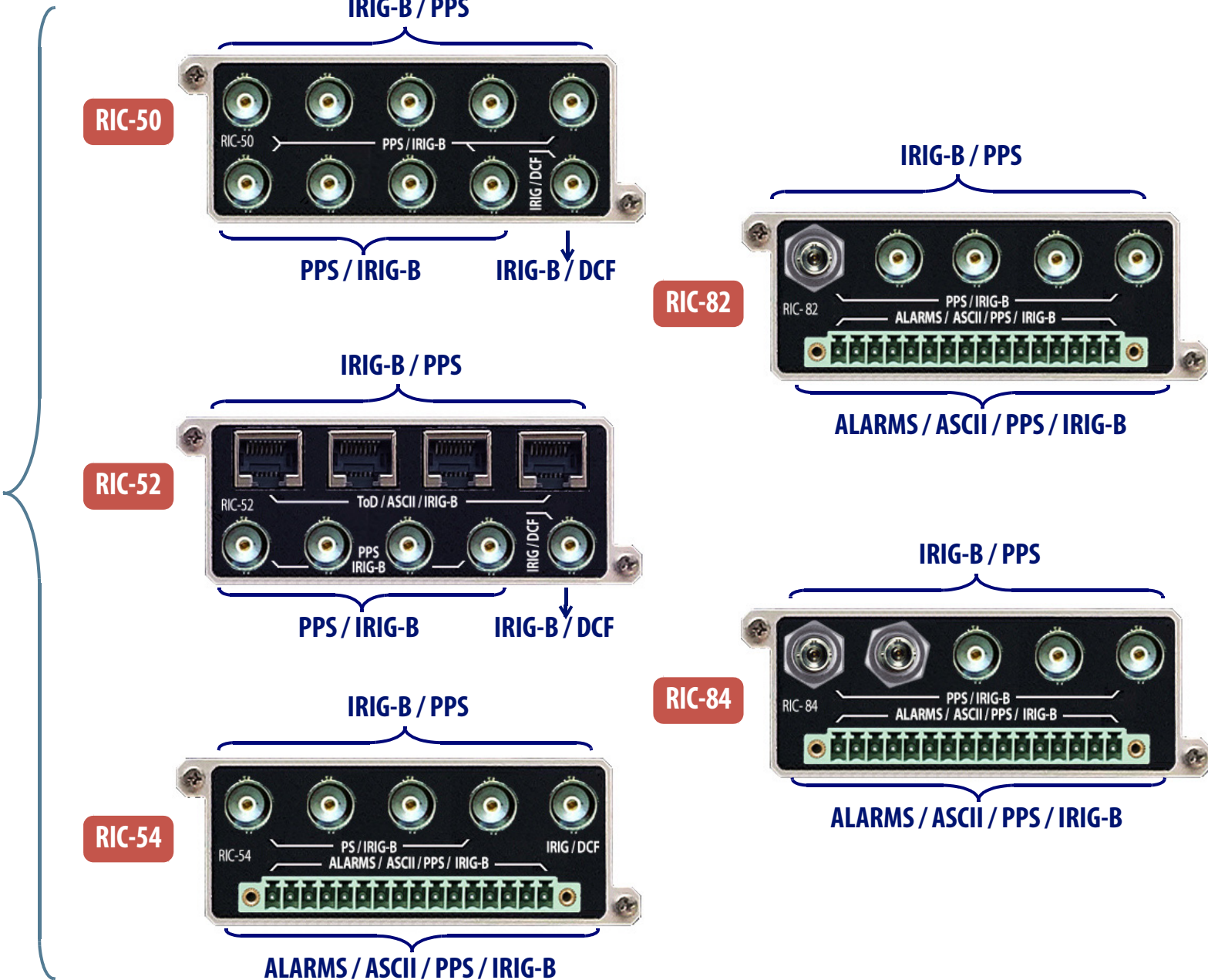
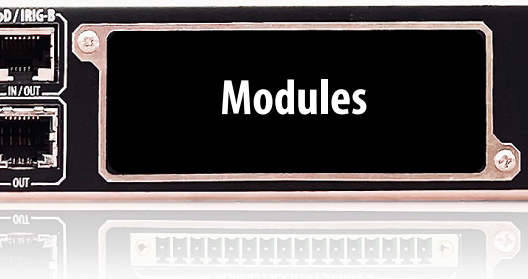

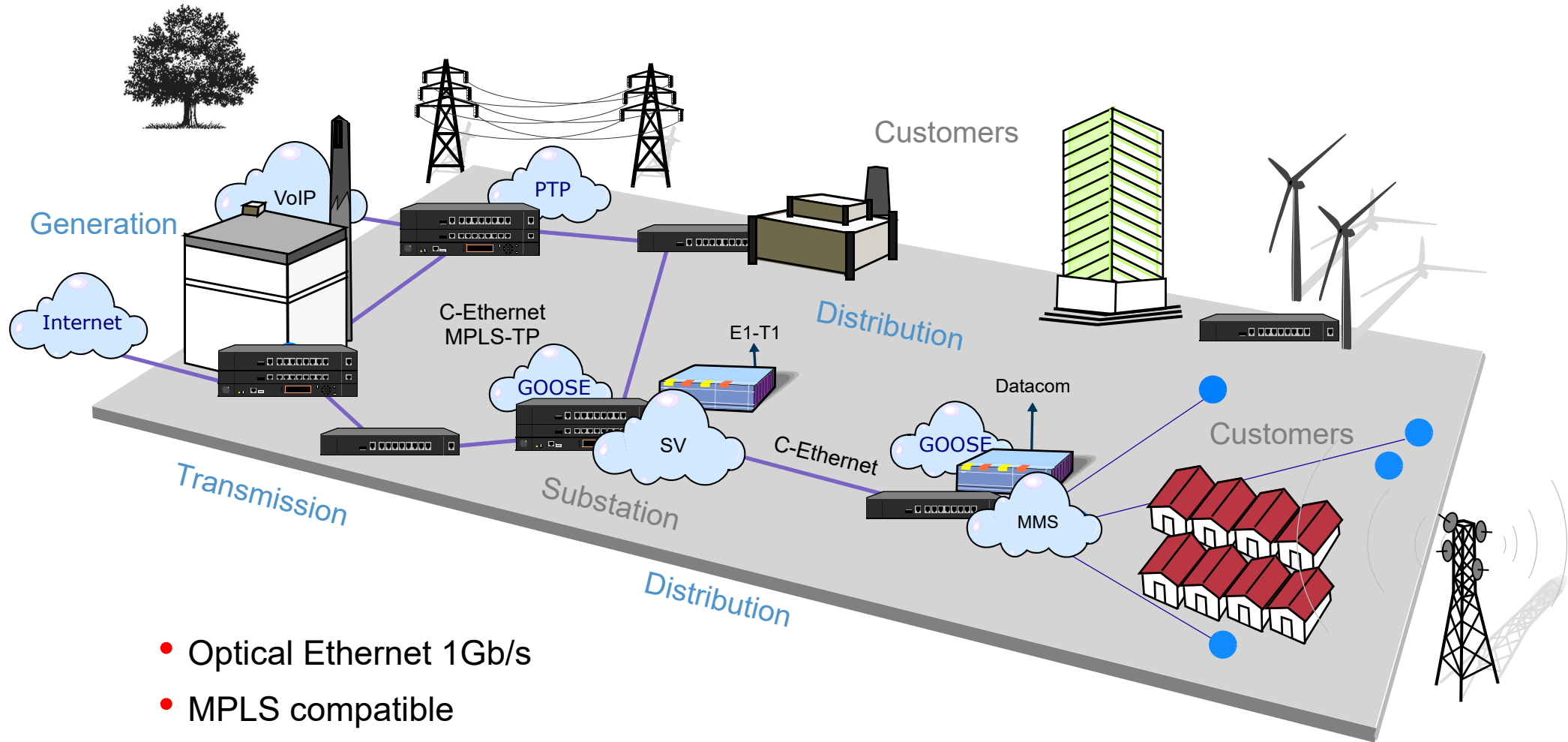

- Optical Ethernet 1Gb/s
- MPLS compatible
- PTP Telecom / Power profiles



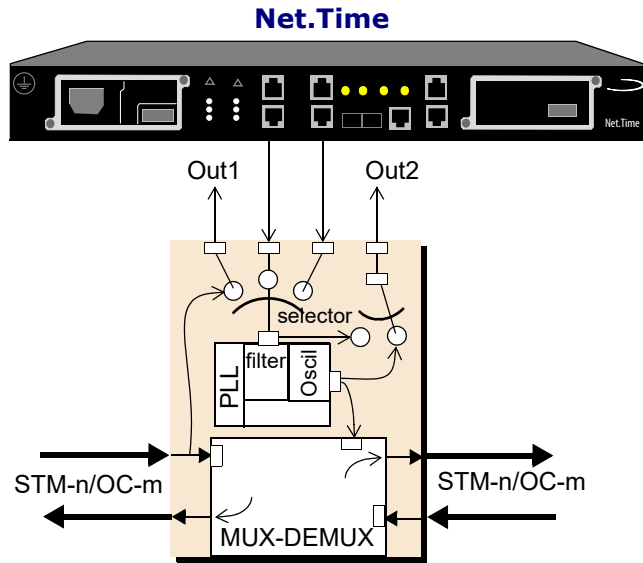

In SDH/SONET there are four ways to synchronize ADM and digital cross connects (DXC):

**1 - External timing:** The NE obtains its signal from a BITS or stand-alone synchronization equipment (SASE). This is a typical way to synchronize, and the NE usually also has an extra reference signal for emergency situations.

**2 - Line timing:** The NE obtains its clock by deriving it from one of the STM-n/OC-m input signals. This is used very much in ADM, when no BITS or SASE clock is available. There is also a special case, known as loop timing, where only one STM-n/OC-m interface is available.

**3 - Through timing:** This mode is typical for those ADMs that have two bidirectional STM-n/OC-m interfaces, where the Tx outputs of one interface are synchronized with the Rx inputs of the opposite interface.

**4 - Internal timing:** In this mode, the internal clock of the NE is used to synchronize the STM-n/OC-m outputs. It may be a temporary holdover stage after losing the synchronization signal, or it may be a simple line configuration where no other clock is available.

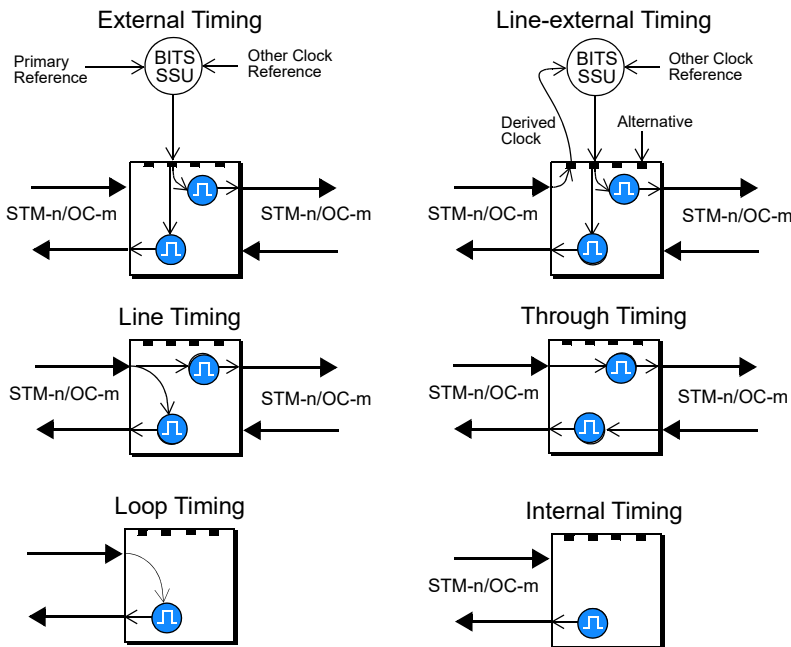

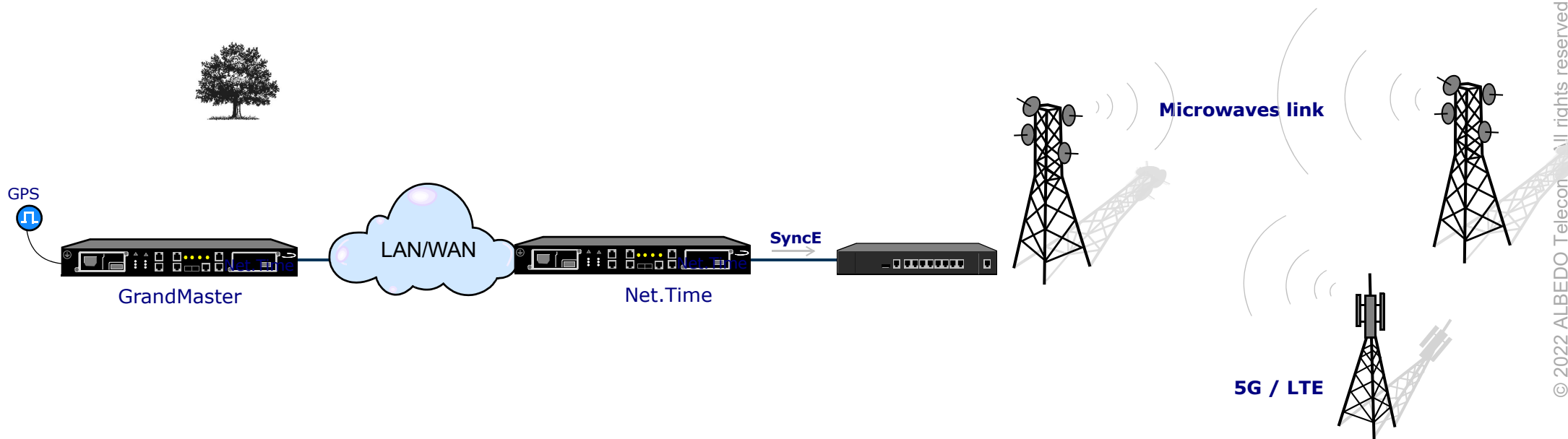

Net.Time supports Synchronous Ethernet over a copper and optical connections. This allows operators to utilize cables on SFP ports and still meet timing and synchronization requirements for demanding applications like LTE in mobile networks and microwaves links.

- Interfaces: RJ45 and SFP
- SyncE input/output
- Full ESMC / SSM support as per ITU-T G.8264 and G.781
- QL 16 bits compatible

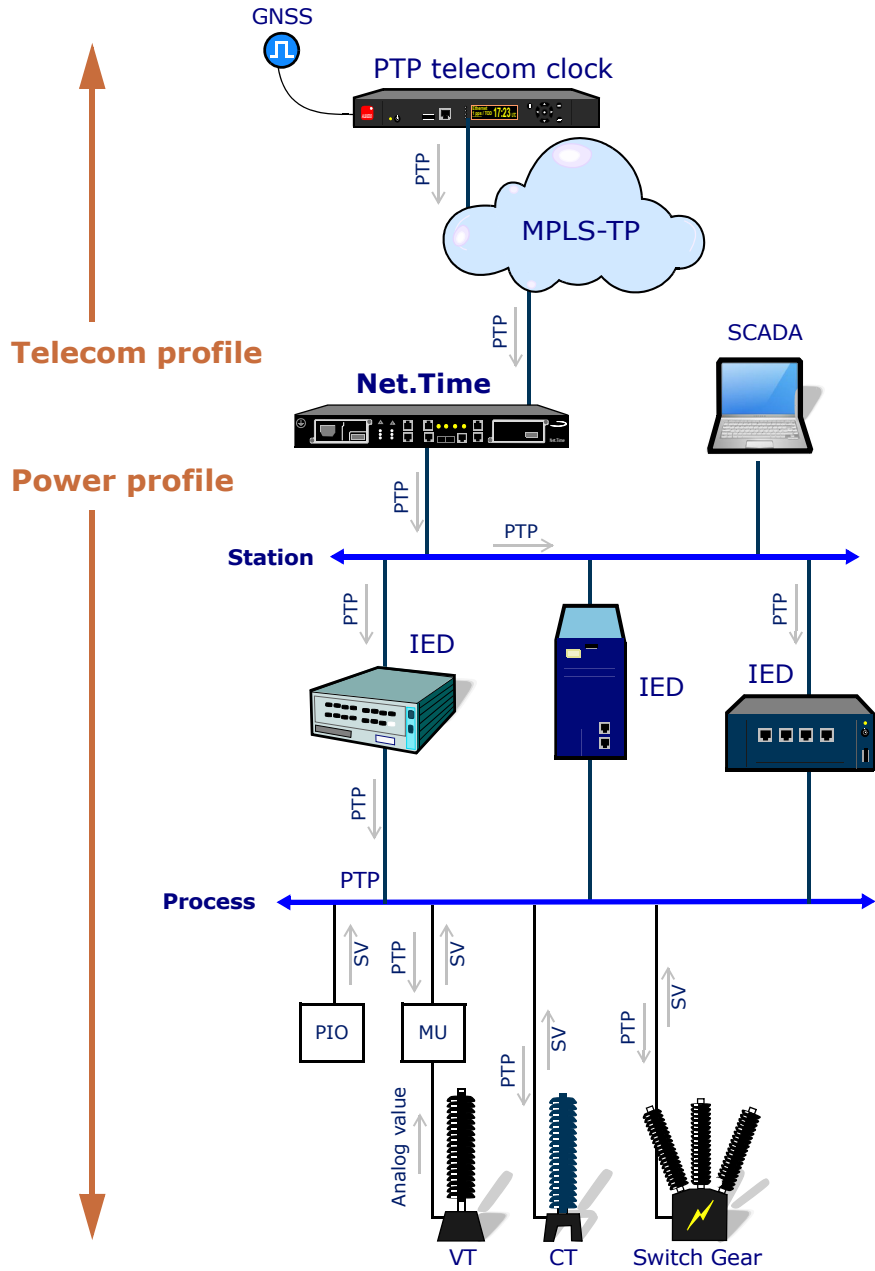

Net.Time supports the following PTP profiles

- Default
- Telecom
- Power
- Utility

Then it is possible to interconnect networks using different synchronization profiles:

- Telecom to Power
- Telecom to Utility
- Power to Telecom
- Power to Utility
- Utility to Telecom

## No need for PTP profile translator Net.Time is a Profile translator

# Substation Timing

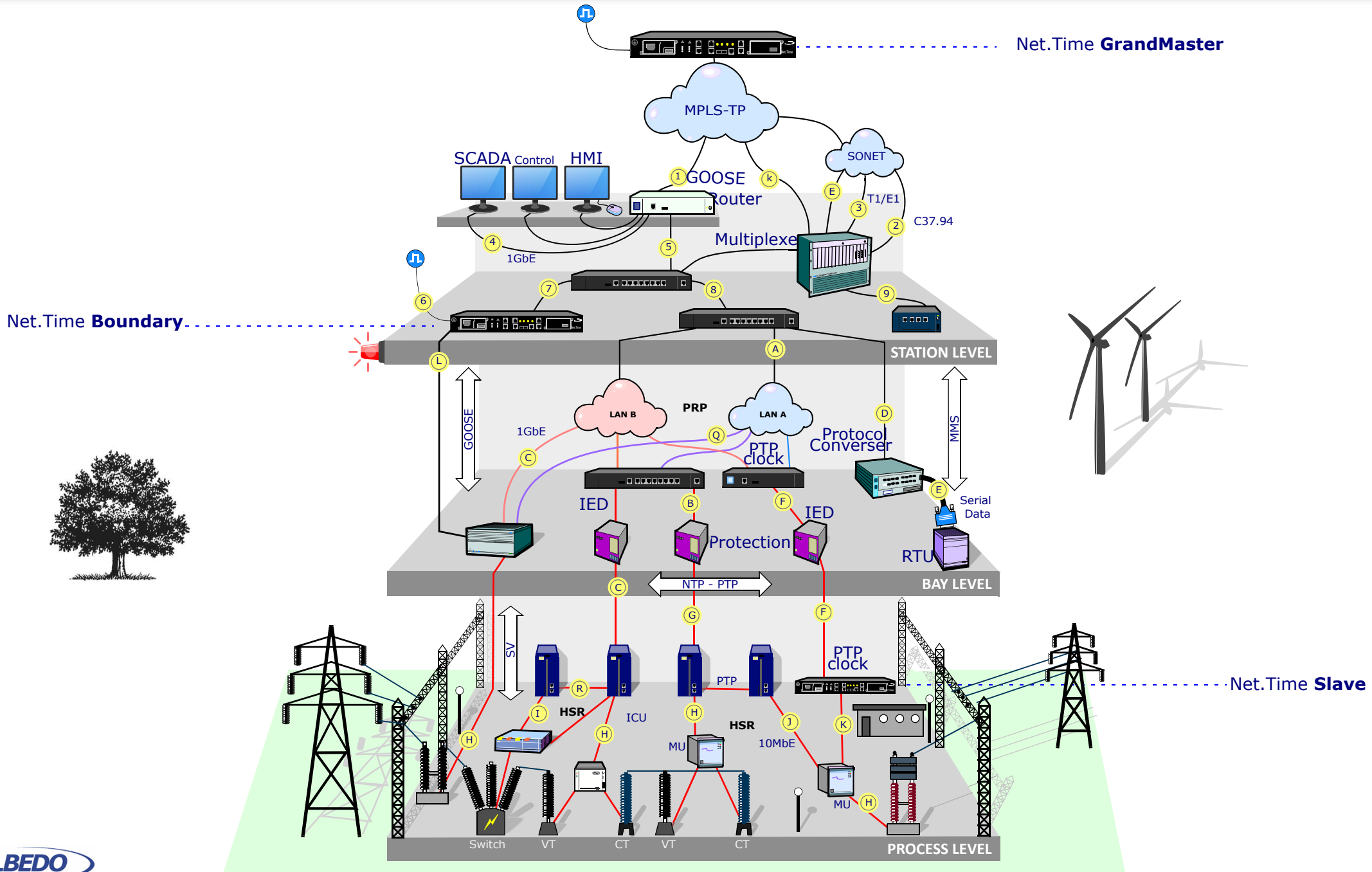

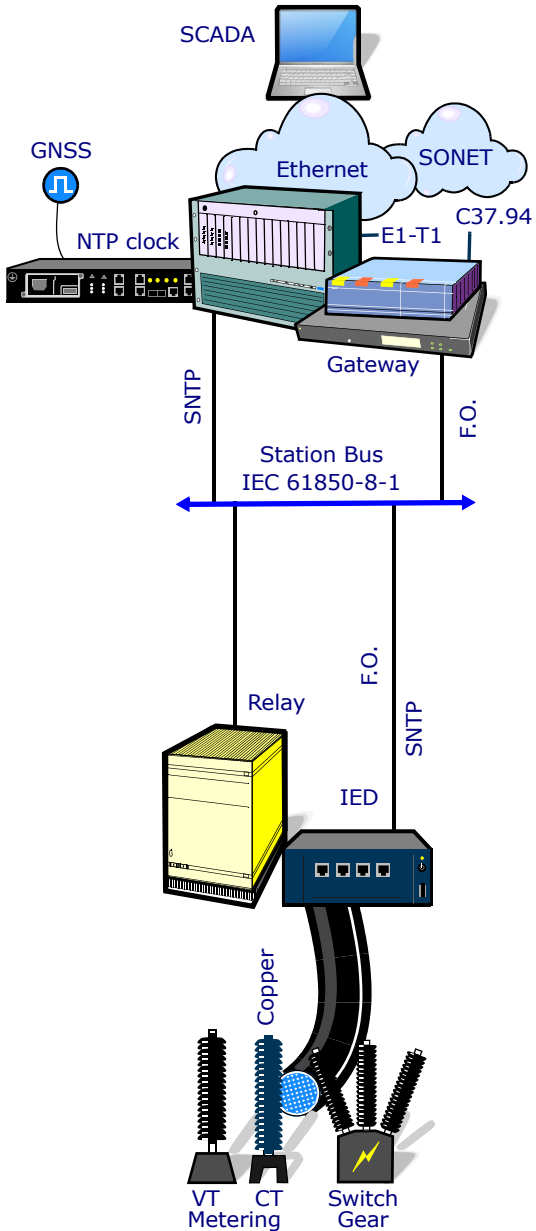

**Conventional**

## Conventional Substation

- IRIG-B
- PPS
- T1/E1

## IEC 61850 substation

- PTP
- PRP
- SyncE
- NTP
- IRIG-B
- PPS
- T1/E1

migration

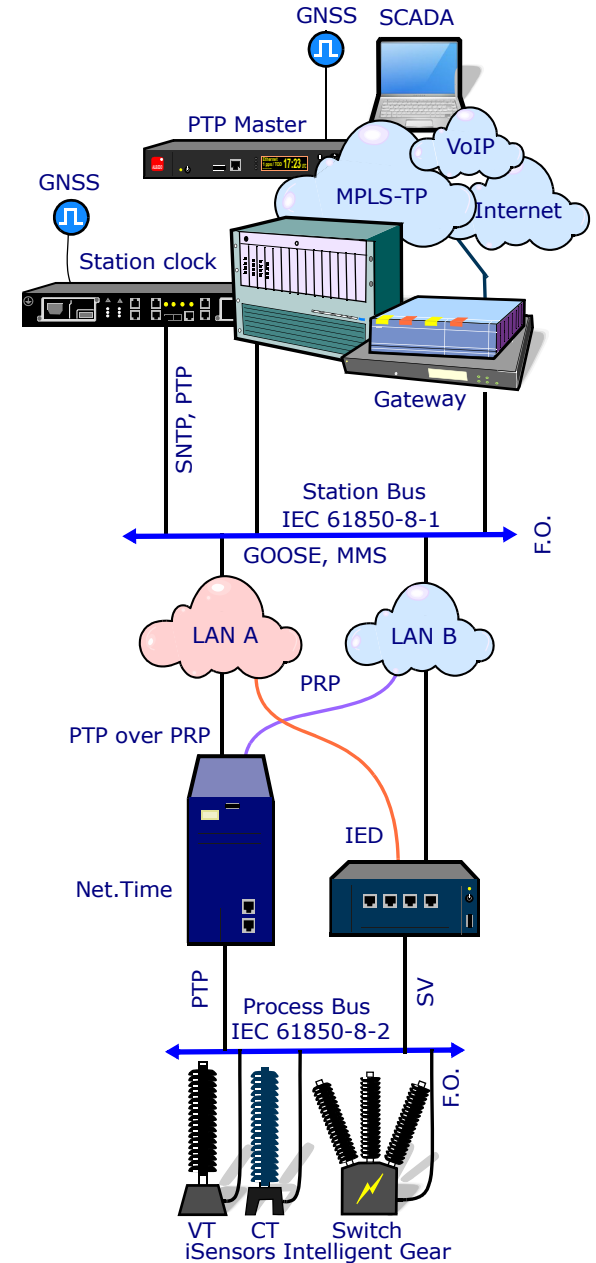

**IEC 61850**



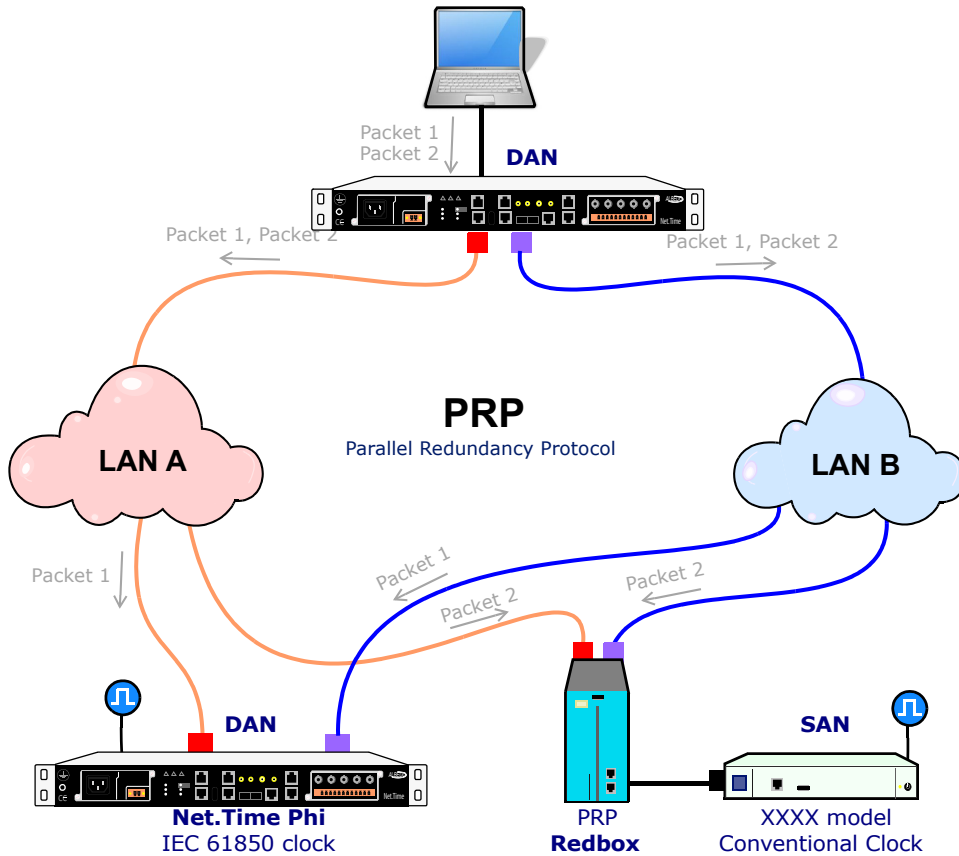

PRP is based on the use of two independent networks. The sender **must send each packet twice** (to LAN A and LAN B) through two separate ports.

The latency of both networks should be similar, if they were very disparate packets would always arrive first through the same network and wait for the second.

We can find two types of devices:

- **DAN** (Double Attached Node) if has PRP support is integrated, then can be attached directly
- **SAN** (Single Attached Node) conventional device without PRP support then a Redundancy Box (RedBox) is required to be connected.

PRP is encapsulated in IP/MAC then it can use conventional networks so LAN A and LAN B can transport any traffic, PRP and non-PRP, and this a nice advantage compared with HSR.

## PRP with zero-time recovery for PTP and NTP

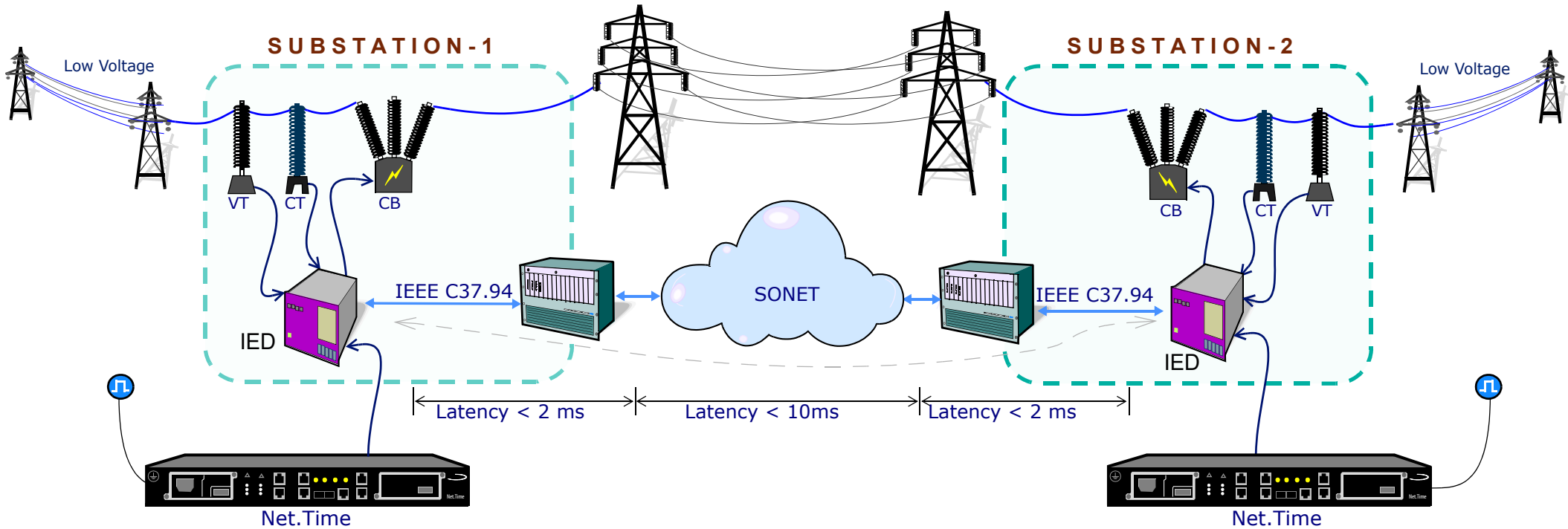

Teleprotection is based on the comparative of electric parameters on both sides of the lines under protection, therefore any strategy requires perfect synchronization of all the elements. Phase synchronization is required to prevent overloads and facilitate reconnection.

## Differential Protection requires permanent Synchronization



Block diagram

GUI web server

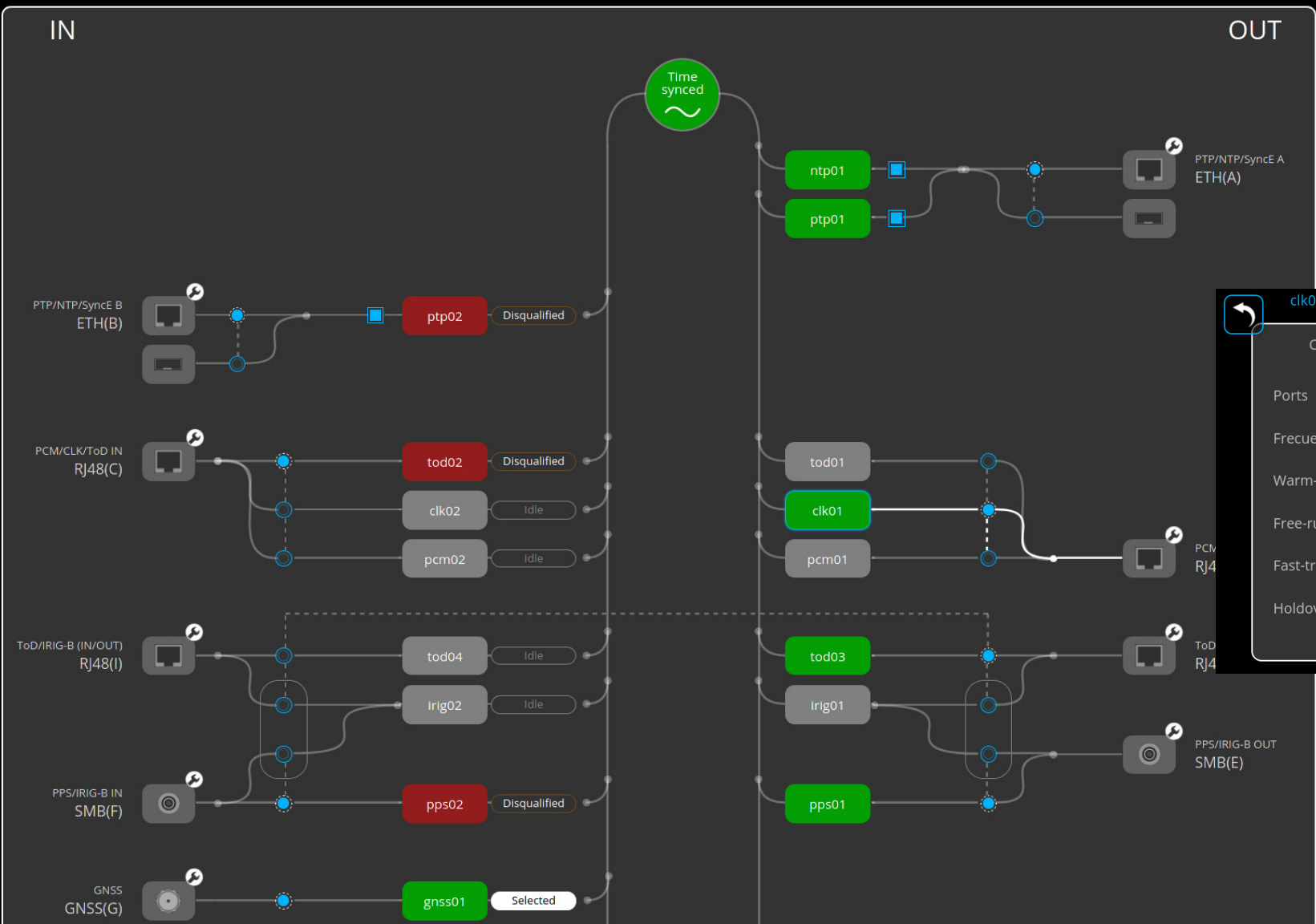

**clk01 Iface Configuration**

Configuration

- Ports:  RJ48(D)
- Frecuency:
- Warm-up:  on  squelch
- Free-run:  on  squelch
- Fast-track:  on  squelch
- Holdover:  on  squelch

## WAN

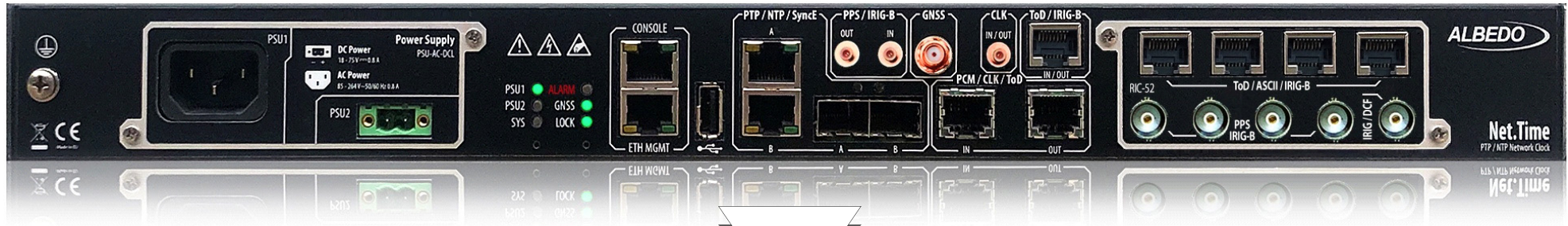

## Substation



That's all



[www.albedotelecom.com](http://www.albedotelecom.com)



**ALBEDO**  
Telecom

*The Path to Excellence*